

**INFRA**  
**PLUS**

**RADIANT HEATING SYSTEMS**

**UNIQUE**

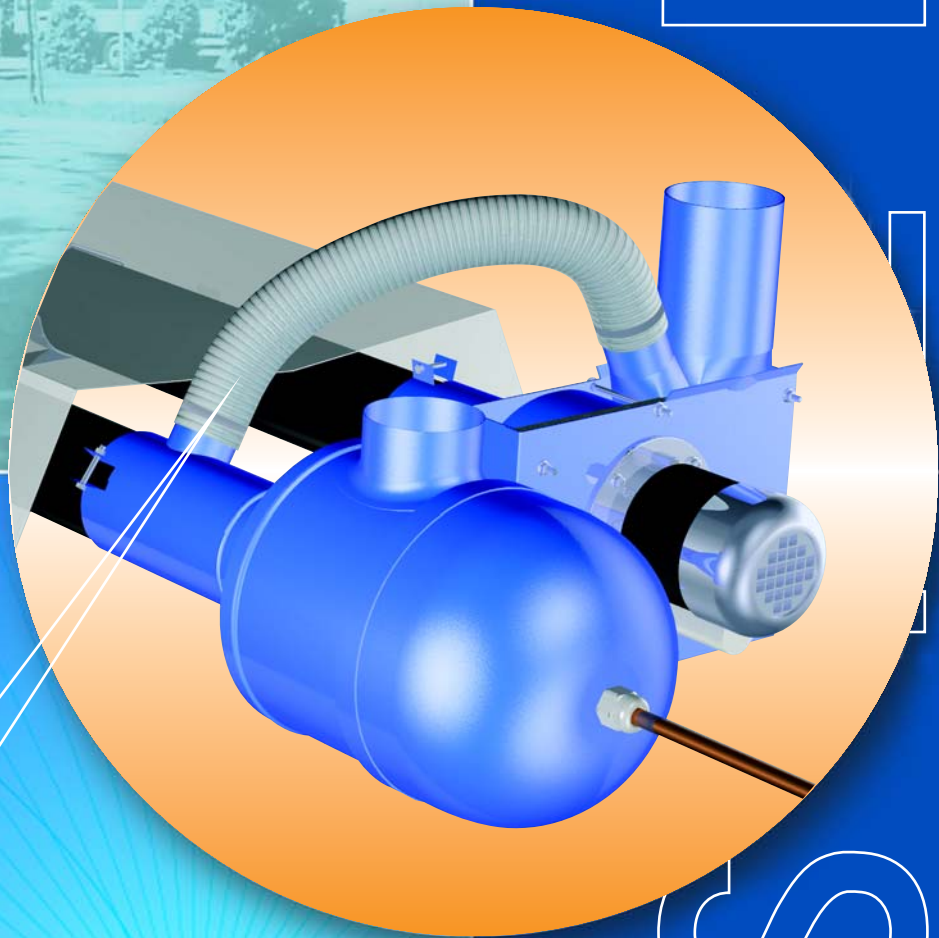

**RECIRCULATION**

**CE**

**PATENTED**



**SYSTEMA**

imita la natura

S  
M  
S  
Y  
S

Infra Plus sealed radiant heaters designed and produced by SYSTEMA S.p.A are composed of:

Sucked burner, **Baf Plus**, pre-mixing air-gas induced by the vacuum placed at the end of the radiant tube, multi gas combustion head available with gas stabilizer made of INOX, electronic spark and ionized flame detection. Gas electro-valve with low starting adjustable by pressure stabilizer and gas filter. Air pressure switch, combustion air dumper adjustable to suit the exact air requirements of the burner. Burner box finished in anti rust paint.

The **Infra Plus R** is available with a **Re-circulation system to recycle the combustion products** to increase the, the heat performance and the radiant efficiency.

**Baf Plus** fan available with class H ventilated electric motor and auto-lube gear C3, 230V ~ 50Hz, IP44, 50/180W, rotor treated against condensation.

**Infra 12R Plus** is provided with a re-circulation system.

The **heat exchanger** is made of special stainless steel tube painted with high temperature paint.

**Turbolator** to maximize balanced heat distribution along the radiant circuit.

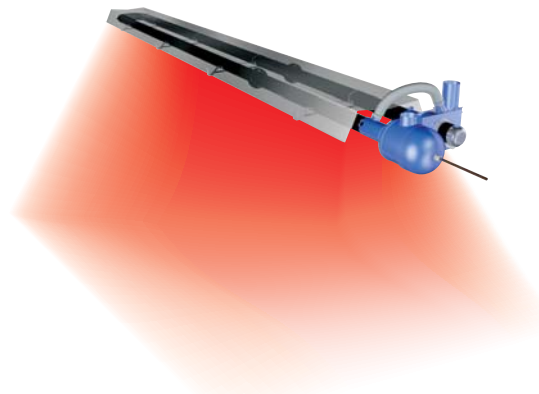

Radiant heating is concentrated to the area where it is required.

Systema radiant heaters are dispatched ready for site assembly. The choice of the materials are based on research and experience over many years to suit any planning criteria in order to give the customer maximum heat efficiency to the area where heat is required.

INFRA PLUS

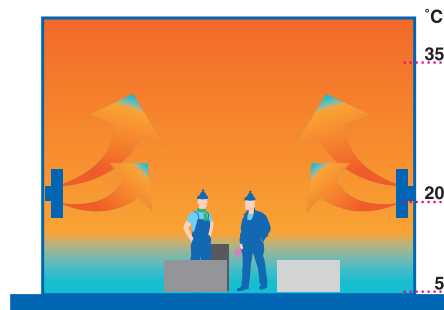

HOT AIR

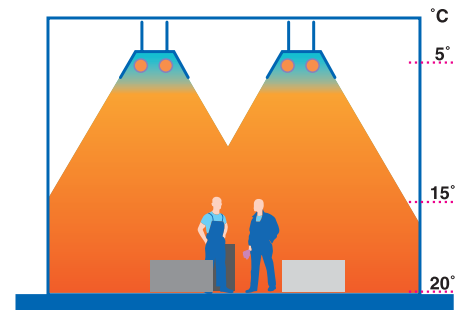

"INFRA PLUS" RADIANT HEATING

## FEATURES

MODEL		INFRA 3 PLUS	INFRA 6 PLUS	INFRA 9 PLUS	INFRA 12R PLUS	
Rated heat flow	kW (Hi)	15	35	53	60	
Working heat output	kW (Hi)	13,9	32,3	47,7	54,3	
Combustion efficiency	%	92,5	92,3	90	90,5	
Rated consumption at 15° and 1013,25mbar	Natural gas G20	Nm³/h	1,59	3,7	5,6	6,34
	LPG. Butane G30	Kg/h	1,18	2,76	4,18	4,73
	LPG. Propane G31	Kg/h	1,16	2,72	4,11	4,66
Electric power supply	V/Hz	230/50	230/50	230/50	230/50	
Max. Absorbed electric power	W	70	70	120	200	
Gas fitting diameter (M)	mm	14	14	14	14	
Air fitting diameter (M)	mm	100	100	100	100	
Fume fitting diameter (M)	mm	100	100	100	100	
Weight	Kg	65	116	173,5	230	

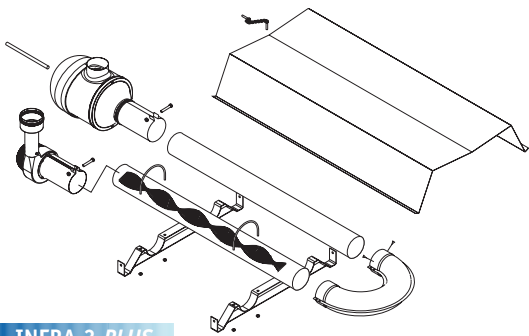

INFRAS 3 PLUS

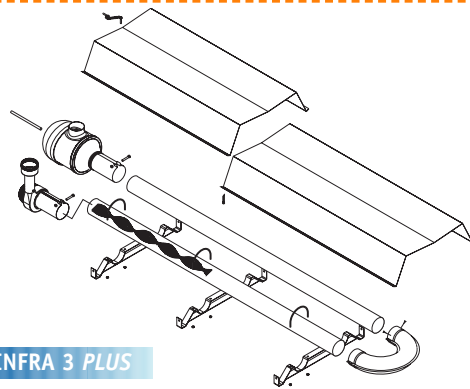

INFRAS 3 PLUS

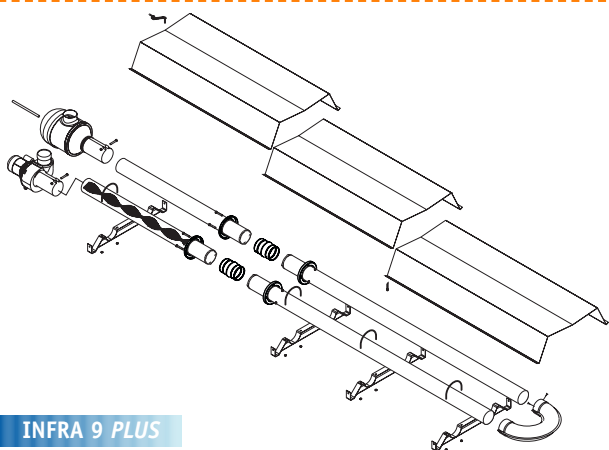

INFRAS 9 PLUS

#### ADVANTAGES:

- Spot heating (multi zone heating)
- Heat concentrated to the area where heat is required
- No air movement
- Limited air stratification
- No dust movement, clean working environment
- Possibility to work in a healthy environment breathing fresh air
- Low thermal inertia of the heating system
- Energy saving

## RECIRCULATION

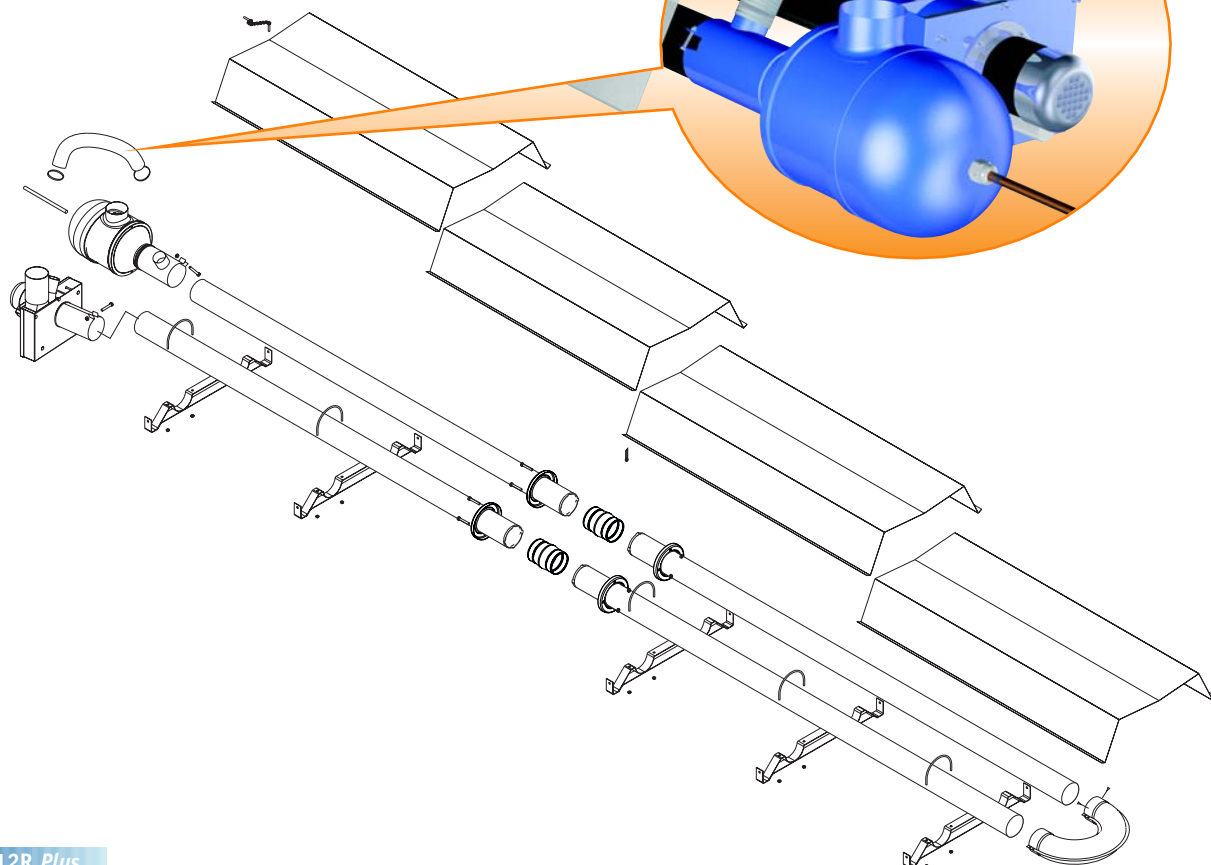

INFRAS 12R Plus

**RADIANT  
HEATING SYSTEMS**

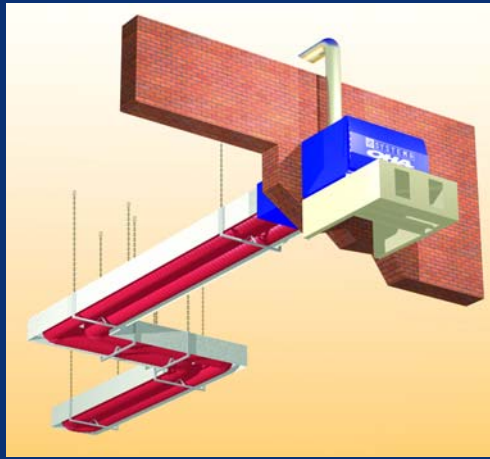

**RADIANT STRIPS**

**PLAQUE HEATERS**



**ROOF-TOP**

**SUSPENDED AND STANDING  
WARM AIR HEATERS**

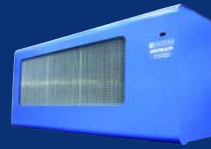

**AIR-SPLIT  
"BREEZE"**



**HEATERS  
GAS**



"EOLO" Warm Air heaters - Standing floor cabinet "Anemos"  
Air Split "Breeze" - Thermal Unit 35 ÷ 70  
Packaged Rooftop Air Conditioners  
"KING" Gas Convector - "ClimaKing" Gas Convector/split



"OHA" Radiant Strips  
"INFRA" Radiant Tubes  
"SCR" Plaque heaters

OUR BRANCHES ALL OVER THE WORLD

SYSTEMA POLSKA sp. z o.o.  
Ul Szadkowska 72  
98220 Zdun'ska Wola - POLAND  
Tel. +48438247287  
Tel./Fax +48438233064  
www.systemapolska.pl -  
systema@systemapolska.pl

SYSTEMA il kwang machine  
industry co., ltd  
730-20 An Chung Dong,  
Kwang San-Ku, Kwang Ju, KOREA  
Tel. +82629542204  
Fax +82629542208  
ilkwang2@chollan.net

SYSTEMA FRANCE s.a.r.l.  
31 Rue Wilson  
69150 Décines FRANCE  
Tel. +33.4.37.48.01.00  
Télécopie: +33.4.78.71.02.46  
systema.france@wanadoo.fr

SYSTEMA UK Ltd  
Suite 1G Eden House  
Enterprise Way  
TN8 6HF, EDENBRIDGE KENT, UK  
Tel. +441732860049  
Fax +441732860384  
systema@systemauk.go-plus.net

SYSTEMA RUS  
Россия, 117105, Москва  
Варшавское шоссе, 17, стр. 5  
Тел. +70959581817  
Факс +70959581809  
E-mail: systemarus@mail.ru

SYSTEMA ROMANIA s.r.l.  
B-dul Mihai bravu 42-62 Sector 2  
021328 BUCARESTI - ROMANIA  
Tel./Fax +40 212521628  
office@systema.ro

SYSTEMA IRAN  
IRAN/TEHRAN  
# 41, 11 STREET, SA'DAT ABAD  
TEL: +98021-22068756  
+98021-22359503  
FAX: +98021-22068755

上海系统设备(中国)有限公司  
瓦特利控制设备(上海)有限公司  
WATER CONTROL EQUIPMENT (SHANGHAI) CO., LTD.  
地址: 中国 - 上海市黄浦区西藏南路765号  
邮编: 201804  
电话: 021-69596759 69596756  
传真: 021-69596759  
e-mail: sales@eyetechchina.com

**SYSTEMA**

*imita la natura*

SYSTEMA S.p.A. - Via S. Martino, 17/23 - S.GIUSTINA IN COLLE (PD)  
loc. Fratte Fontane Bianche - PADOVA ITALY  
Tel. 049/9355663 r.a. - Fax 049/9355699  
E-mail: systema@systema.it - <http://www.systema.it>

MANUFACTURER OF GAS-FIRED HEATING SYSTEMS - RADIANT STRIPS - RADIANT TUBES - PLAQUE HEATERS - WARM AIR HEATERS -  
GAS CONVECTORS - INDUSTRIAL OVENS - GAS LiBr ABSORPTION WATER CHILLER/HEATER

In order to improve the quality of its products, SYSTEMA S.p.A. reserves the right to make amendments and changes to the characteristics in this catalogue without previous notice.