

Installation, Operation and Service Instructions

VARIOMAX

(one-stage)	(two-stage)
VARIOMAX 06 / 1	VARIOMAX 06 / 2
VARIOMAX 12 / 1	VARIOMAX 12 / 2

Read and thoroughly understand these instructions before attempting any installation.

Should you have any questions regarding these instructions, please contact:

GoGaS Goch GmbH & Co. KG

Zum Ihnedieck 18

D-44265 Dortmund

Germany

Tel.: +49 (0)231 46505-0

Fax.: +49 (0)231 46505-88

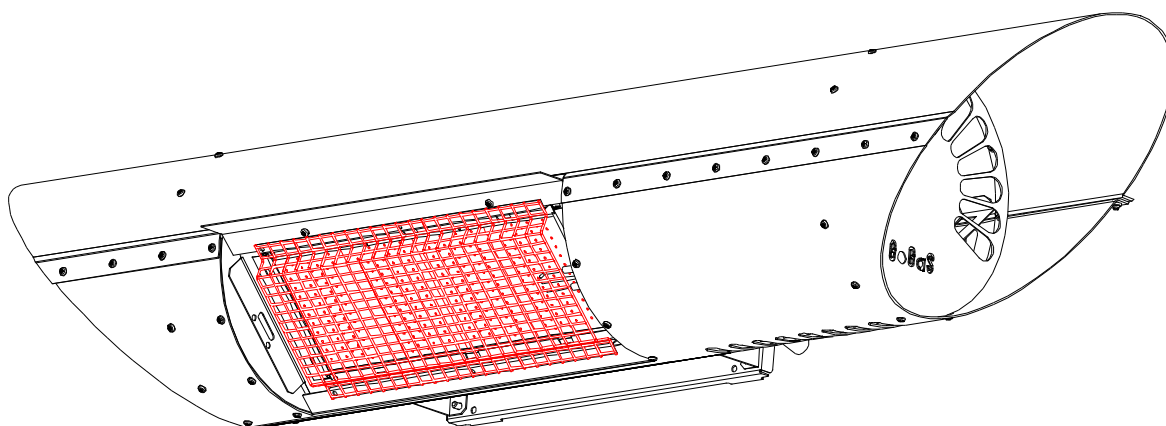

CE-0085AU0204

Product Identification No.

Preface

Intended Use

The GoGaS **VARIOMAX** high intensity heater is intended to be used for the heating of commercial and industrial covered open spaces and halls. The appliance must be protected from splash water. An appropriate ventilation of the halls is required, according to local standards and regulations. European standards require a positive air displacement of 10 m³ per installed kWh.

The Technology

The **VARIOMAX** is a high-quality product and is available in two ratings (6 kW and 12 kW). The modern injector burner allows for either one- or two-stage operation. The two-stage operation is achieved by means of a double nozzle (100% full load / 50% half load at constant manifold pressure). A special double layered radiation grille ensures a stable operation in windy conditions and increases the radiant efficiency. The combustion chamber, control unit and gas train are protected by a case.

Controls

The **VARIOMAX** can be operated as a one- or a two-stage heater. For two-stage heaters, a double nozzle allows two-stage regulation under constant gas pressure. The gas flow is controlled by changing nozzle orifice size.

This instructions manual is subject to change without notice.

Table of Contents

1. Safety Considerations	4
2. General Information.....	5
3. Energy supply	6
4. Heater Mounting Instructions.....	7
5. One-stage Heater Startup	10
6. Two-stage Heater Startup	11
7. Troubleshooting	13
8. Service and Maintenance	14
9. Changeover to different gas type.....	15
10. Setting Nozzle Pressure for One- and Two-Stage Heaters	16
11. Minimum Mounting Height	17
12. Minimum Clearance to Combustibles.....	18
13. Nozzle Pressures Table.....	19
14. Technical Data.....	19
15. Illustration: Connection of the Control Unit.....	20
16. Spare Parts List	21

1. Safety Considerations

Used Symbols

Following warning icons are used to indicate hazards:



Warning - failure to comply may result in personal injury and property damage.



Warning about working with electrical equipment.

Only the manufacturer or an approved installing or service company are allowed to perform work on this heater, complying with the local standards. This heater must be installed and serviced only by the manufacturer or by personnel, who have been trained, qualified and understand all applicable codes. In Germany, only the manufacturer or an approved installing or service company are allowed to perform work on this heater, complying with the DVGW-Arbeitsblatt G 676.



This appliance must be installed in accordance with current connection and installation regulations and may only be used in adequately ventilated rooms. The installation and operating instructions must be thoroughly read and understood before installation, startup and service.



Before installation it must be checked if local gas distribution, gas type, gas pressure and the settings of the appliance are compatible with each other.

2. General Information

GoGaS infrared heaters are manufactured in accordance with DIN EN 419. Each appliance is subjected to a function test before it leaves the factory and is preset to the relevant gas type. When installing and operating radiant heaters, the local regulations and guidelines must be complied with. In Germany, these are:

Aufstellung von Strahlungsheizungsanlagen (<i>Installing Radiant Heating Systems</i>)	DVGW Arbeitsblatt G 638/I
Technische Regel für Gasinstallation (<i>Technical Rules for Gas Installations</i>)	DVGW Arbeitsblatt G 600 TRGI 1986/96
Technische Regel Flüssiggas (<i>Technical Rules for Liquid Gas</i>)	TRF 1996
Technische Regel für die mechanische Abführung der Abgase von Feuerstätten (<i>Technical Rules for Mechanical Elimination of Heating System Flue Gas</i>)	DVGW G 660
Regeln für Berechnung des Wärmebedarfes von Gebäuden (<i>Rules for Calculating Heat Load for Buildings</i>)	DIN 4701
Sicherheits-technische Ausrüstung von Heizungsanlagen (<i>Safety-related Equipment for Heating Systems</i>)	DIN 4751
Gasfeuerungen in Heizungsanlagen (<i>Gas Firing Equipment in Heating Systems</i>)	DIN 4756
Bestimmungen für das Errichten von Starkstromanlagen (<i>Regulations for High Voltage Systems Installation</i>)	VDE 0100
Allgemeine Anforderung für die elektr. Sicherheit (<i>General Requirements for Electrical Safety</i>)	VDE 0702
Technische Anschlussbedingungen Der örtlichen Energieversorgungs- Unternehmen (<i>Technical Requirements of the Local Power Supply Company</i>)	TAB
Landesbauordnung (<i>Regional Building Regulations</i>)	LBO
Feuerungsverordnung der Länder (<i>Regional Firing Installations Regulations</i>)	FeuVO

3. Energy supply

Gas connection: R ½ male thread

Connection	Gas supply line pressures	
	Maximum	Minimum
Nat. gas G20	100 mbar	20 mbar
Nat. gas G25	100 mbar	20 mbar
Propane G31	100 mbar	60 mbar



Gas consumption: see Ch. 14. "Technical Data"

Electrical connection

Alternating current AC Voltage 230 V, 50Hz with L, N and PE

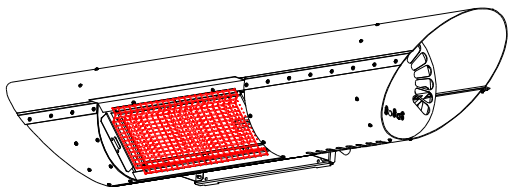
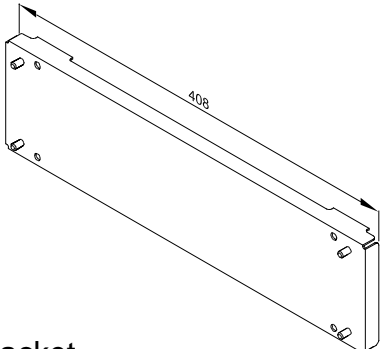
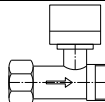

Power consumption: 12 W for one-stage heaters
32 W for two-stage heaters

Parts Overview VARIOMAX 6

Item	Qty.	Description	Size	DIN / EN	Illustration
Item. 1					
Item. 2					
6 kW Heater		Wall Bracket			
3	4 Pcs.	Washer	6,4	125	
4	4 Pcs.	Hexagonal nut	M 6	24034	
5.1	1 Pcs.	Ball valve		1/2"	
5.2	1 Pcs.	Screw connection		1/2"	

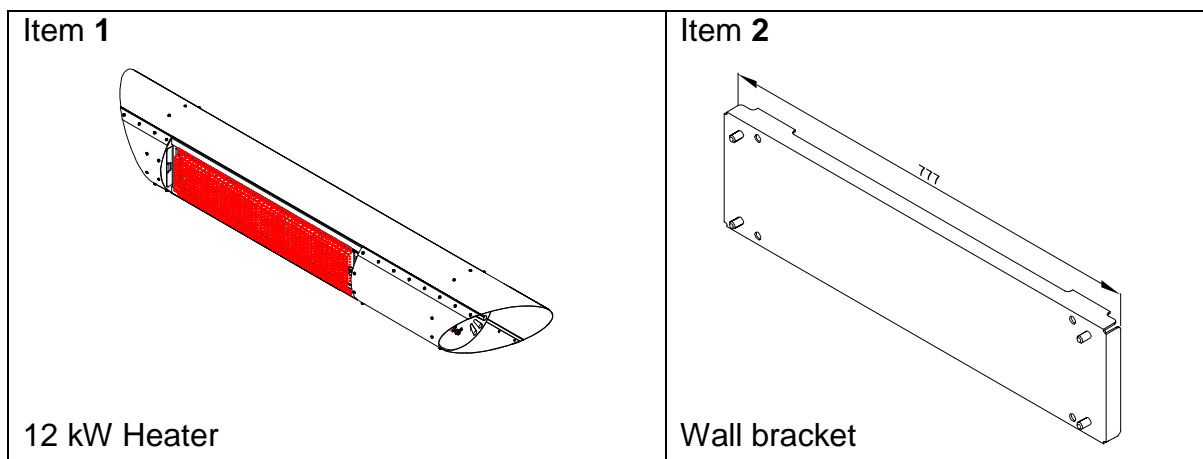
Parts Overview VARIOMAX 12

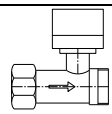

Item	Qty.	Description	Size	DIN / EN	Illustration
3	4 Pcs.	Washer	6,4	125	
4	4 Pcs.	Hexagonal nut	M 6	24034	
5.1	1 Pcs.	Ball valve		1/2"	
5.2	1 Pcs.	Screw connection		1/2"	

4. Heater Mounting Instructions

The **VARIOMAX** heater is preset in the factory and is delivered ready to install. The heater is positioned at a 45° mounting angle which may not be changed. We recommend first mounting the heaters and afterwards installing the gas piping.

The ball valve can be positioned in such a way that it is easily accessible, but hidden from sight. In case of a radio remote control operation, the receivers should be positioned in such a way that the radio waves are not covered by the heater body.

For facilitating the mounting, the heater is equipped with a mounting plate.

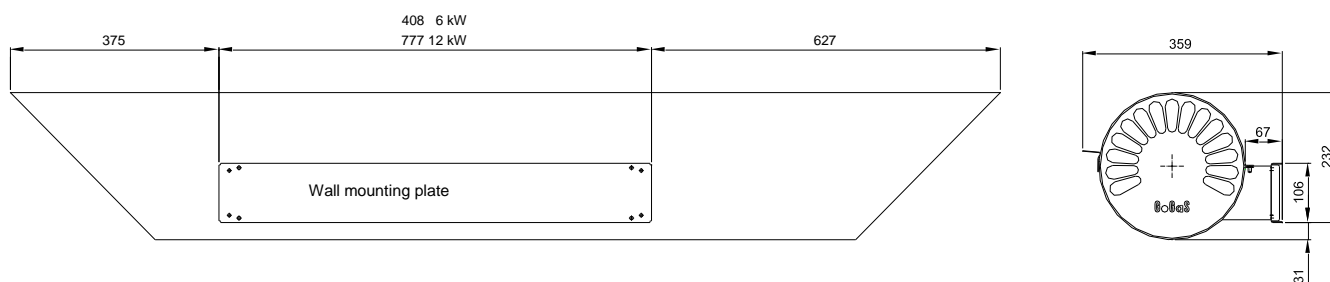

Mounting Procedure:

- Place the mounting plate on the wall, marking the position of the holes.
Fasten to wall.

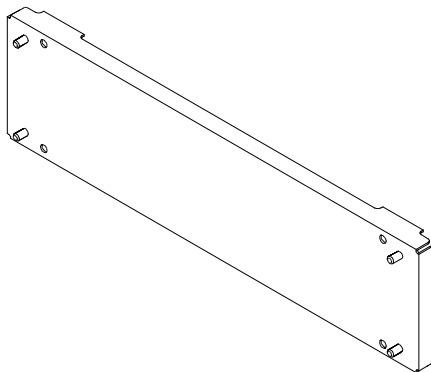

- Position the heater on the bolts of the mounting plate
- Put the washer (3) and the hexagonal nut (4) on the upper bolts
- Without using tools, screw the hex. nuts until the end

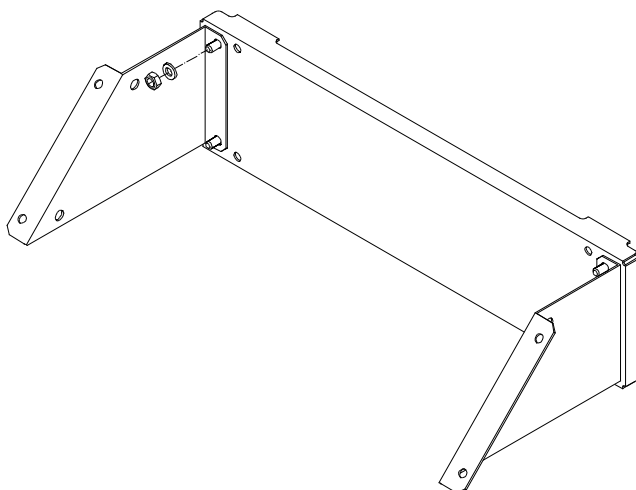

- Now screw the lower washer (3) and the hex. nut (4)
- Screw all six hex. nuts tight, using tools.

Gas Connection:

- Put sealant on the 1/2" fitting of the gas hose and tighten the (5.2) screw connection.

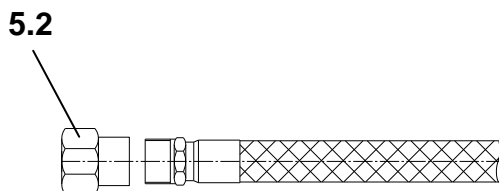

- Install ball valve on the gas pipe.
- Close the ball valve.
- Connect the **(5.2)** screw connection to the ball valve

Electrical Connection:

The switching and control system is designed for an input voltage of 230 V, 50 Hz alternating current with ground lead and operates in the VDE¹-approved tolerance range of -15% to +10%. Power consumption 12 W (32 W for two-stage heaters). Input voltage to be checked before startup.

One-stage Electrical Connection

- Lead the three-wire cable of the heater to the power supply and connect.

Wiring / Connection cables

Brown or "1" = L

Blue or "2" = N

Green / yellow = PE

Two-stage Electrical Connection

- Lead the four-wire cable of the heater to the four-wire power supply and connect.

Wiring / Connection cables

Brown or "1" = L

Blue or "2" = N

Black or "3" = two-stage switching (terminal 4 in controller)

green / yellow = PE



Ensure correct polarity of electric connection. Make sure to ground the system.

¹ Verband Deutscher Elektrotechniker

5. One-stage Heater Startup

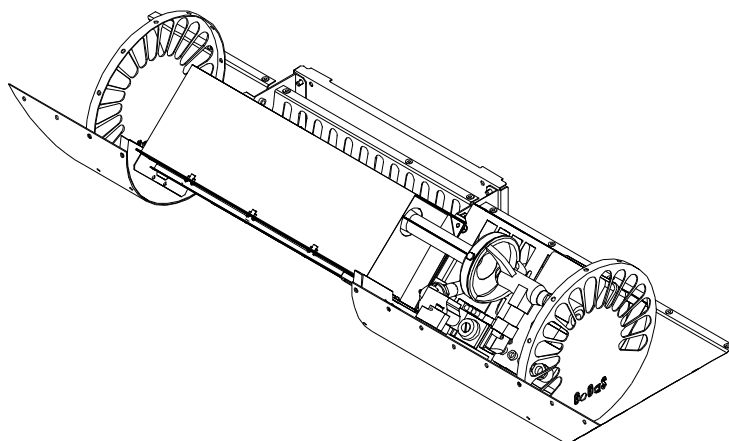

a) Open the gas valve and measure the gas supply line pressure at the test socket (see Fig. Combination Valve – Top View) The connected gas supply pressure must comply with the specifications in Ch. 3 “Energy Supply”, otherwise the startup must be interrupted.

Perform leak test at the ball valve and the screw connection up to the gas hose.

In case of appropriate gas supply pressure, the heater may be turned on using the respective switching system (either manual switchbox or switching- and control system).



Measure the gas supply pressure again during full load operation. If the gas pressure is too low, the operation must be interrupted. After measurement, close gas pressure test socket.

b) Operating Sequence of the SG 300 Controller

- Connect electricity to unit.
 - 1.5 sec after switching on, the igniter creates a high-voltage spark and, simultaneously, the solenoid gas valve opens.
 - If after an ignition attempt of max. 30 sec. no flame is recognized by the ionization flame monitoring module, the ignition stops and the gas valve closes (the heater shuts down for safety and sends a failure report).
 - If during the ignition attempt (max. 30 sec.) a flame appears and creates an ionization current $\geq 0.8\mu\text{A}$, the ignition stops and the unit remains in operation.
- Reset after safety shutdown
 - The heater needs to be disconnected for at least 5 sec. Afterwards repeat ignition as described above.
- Reigniting
 - If a malfunction occurs during operation, the igniter will automatically turn on for a maximum duration of 30 sec. If no ionization current is recognized within this ignition attempt period, the heater goes into safety shutdown.

c) Checking Nozzle Pressure

- Connect pressure measuring device to nozzle test nipple (see Fig. Combination Valve – Top View)
- Turn on heater
- Compare measured nozzle pressure to rating plate specifications. If necessary, use pressure regulator to correct.

6. Two-stage Heater Startup

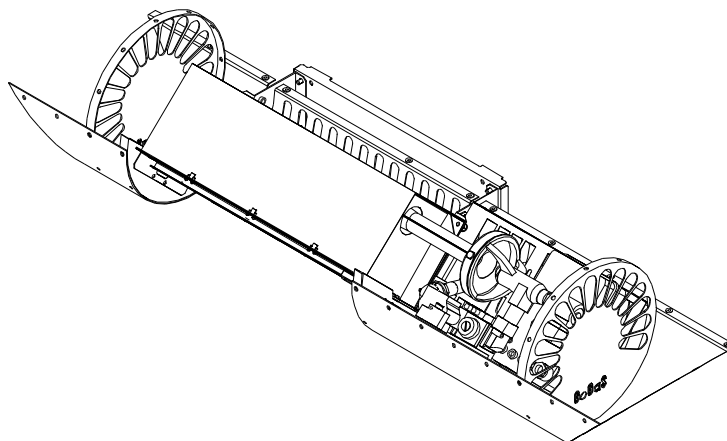

For the two-stage **VARIOMAX**, the power control is not performed through conventional pressure level changing. It is performed by means of a **double nozzle with High-low valve** which allows two-stage regulation under constant gas pressure. The input load is controlled by changing nozzle orifice size. At full load, the two nozzle orifices are open. At half load, an electrically operated rod closes one of the orifices. In this position the heater receives only 50% of the nominal input load.

a) Open the manual gas valve and measure the gas supply line pressure at the test socket (see Fig. Combination Valve – Top View). The connected gas supply pressure must comply with the specifications in Ch. 3 “Energy Supply”, otherwise the startup must be interrupted.

Perform leak test at the ball valve and the screw connection up to the gas hose.

In case of appropriate gas supply pressure, the heater may be turned on using the respective switching system (either switchbox or switching- and control system).



Measure the gas supply pressure again during full load operation. If the gas pressure is too low, the operation must be interrupted. After measurement, close gas pressure test socket.

b) Operating Sequence of the SG 300 Controller and Two-Stage Operation

- Connect electricity to unit.
The voltage applied to the solenoid valve turns the heater on at full load.



The heater switches on correctly only at full load.

- 1.5 sec after switching on, the igniter creates a high-voltage spark and, simultaneously, the solenoid gas valve opens.
 - If after an ignition attempt of max. 30 sec. no flame is recognized by the ionization flame monitoring module, the ignition stops and the gas valve closes (the heater shuts down for safety and sends a failure report).
 - If during the ignition attempt (max. 30 sec.) a flame appears and creates an ionization current $\geq 0.8\mu\text{A}$, the ignition stops and the unit remains in operation.
- Reset after safety shutdown
 - The heater needs to be disconnected for at least 5 sec. Afterwards repeat ignition as described above.
- Reigniting
 - If a malfunction occurs during operation, the igniter will turn on for a maximum duration of 30 sec. If no ionization current is recognized within this ignition attempt period, the heater goes into safety shutdown.

c) Checking Nozzle Pressure

- Connect pressure measuring device to nozzle test nipple (see Combination Valve – Top View)



Switch heater on at full load

- Compare measured nozzle pressure to rating plate specifications. If necessary, use pressure regulator to correct. For correct nozzle pressures refer to Table in Ch. 13.

d) Testing Two-Stage Operation

- Switch on heater at full load and allow 10 to 15 min. to burn until the ceramic tiles glow brightly.
- Switch heater to half load and allow 10 to 15 min to burn. The ceramic tiles will turn considerably darker.
- Switch back to full load.

7. Troubleshooting

Symptom	Possible cause
No spark, no ignition.	<ul style="list-style-type: none"> • No power to control unit • Controller defective • Spark electrode defective • Ignition wire defective or loose
Heater sparks but will not light.	<ul style="list-style-type: none"> • No gas supply • Combination valve will not open • Check nozzle pressure • Nozzle is dirty or clogged <p>Just in case of two-stage heaters:</p> <ul style="list-style-type: none"> • High-low valve is stuck • High.low solenoid defective
Heater lights but locks out after about 30 sec.	<ul style="list-style-type: none"> • Reverse polarity on electric supply • Flame monitoring sensor (ionization electrode) defective • Flame sensor wire defective or loose • Control unit defective
Heater lights for several minutes but then shuts down. After repeated ignition it remains in operation.	<ul style="list-style-type: none"> • Flame monitoring sensor (ionization electrode) damaged
Heater back-fires.	<ul style="list-style-type: none"> • Ceramic tiles damaged • Sealing of the ceramic tile to the burner body damaged

8. Service and Maintenance

Warning



Before servicing and maintenance make sure to close the gas valve and cut electrical power to the heater off. The heater must be de-energized and secured against switching on!

Infrared heaters are to be serviced at least once per year according to local codes. In Germany, these are DIN 4756 and DVGW-Arbeitsblatt G 638/I.

To ensure a safe, economical and stable operation, the operator of the radiant heating system should allow the performing of inspection and service by the power utility company, by the manufacturer of the system or by approved installation companies.

This heater must be serviced only by a trained gas service technician. Only personnel who have been trained and understand all applicable codes should undertake the service.

Particularly following tasks have to be completed during the inspection and maintenance:

Cleaning

Dust the reflectors and combustion chamber and remove encrustations. Clean the ceramic tiles with dry air blower (do not use compressed air). Remove dirt from the electrode assembly.

Inspection

Following settings and components must be inspected:

- Check and correct nozzle pressure
- Check even distribution of load on the ceramic tiles
- Check quality of combustion - according to German standards: the max. CO content in flue gas is 1000 ppm. Comply with local standards!
- Check tiles for cracks
- Check radiation mesh and mesh support strip for wear
- Check electrodes for correct position or wear
- Check condition of combustion chamber and reflectors
- Check condition of mounting kit
- Check electrical connections
- Check all gas-carrying components (from ball valve gas connector to nozzle)
- Check operation of control system, switchbox

Eventual Defects

The operator must be informed of any found defect and of the necessity of corrective maintenance and/or part replacements that must be done.

Maintenance of the actuators and flame monitoring modules as well as of other safety devices may only be performed by the manufacturer or by his representative. However, the appointed service technician is allowed to replace entire components or assemblies with appropriate parts.

The operator is recommended to sign a service contract in order to make sure a yearly maintenance of the heating installation is performed.

At the end of a service and maintenance intervention, the entire installation must be switched on to confirm the correct operation of the heaters.

9. Changeover to different gas type



Before servicing and maintenance make sure to close the gas valve and cut electrical power to the heater off. The heater must be de-energized and secured against switching on!

The changeover will be performed in the following steps:

- For new nozzle orifice, new air plate and new nozzle pressures see Ch. 13
- Use open-end wrench size 24 and box-end wrench size 30 to unscrew nozzle piece **(2)**.
- Insert and fix new nozzle piece.
- Unscrew the 4 hexagonal screws M8 from the nozzle housing **(4)**.
- Change air plate **(5)** (embossing to the outside)
- Fix nozzle housing again.
- Turn on gas and power.
- Adjust nozzle pressure accordingly.
- Close test nipple.
- Perform leak-test.
- Change the rating plate according to the current settings.

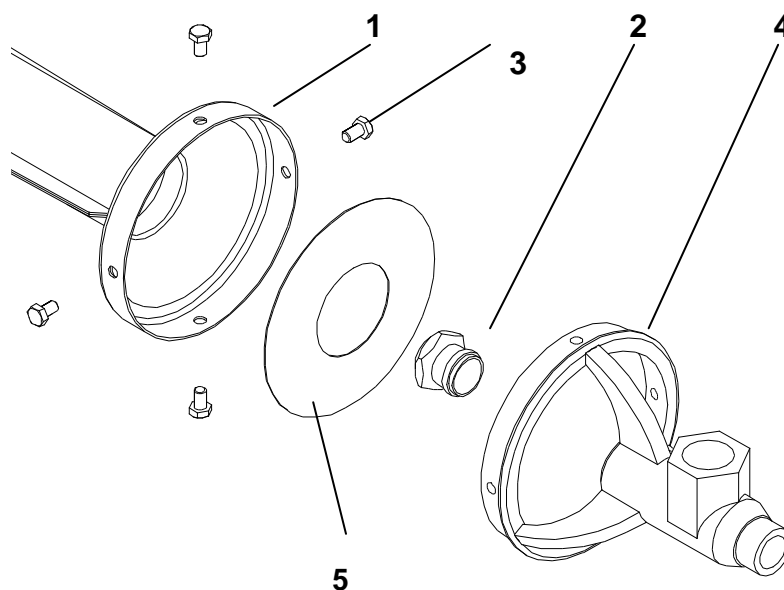

10. Setting Nozzle Pressure for One- and Two-Stage Heaters

- Switch heater on at full load.
- Open nozzle test nipple and connect measuring device.
- Open pressure regulator cap.
- Turn right – increase pressure / turn left – decrease pressure.
- Set correct nozzle pressure.
- Close pressure regulator cap.
- Close test nipple.

Fig. Combination Valve – Top View

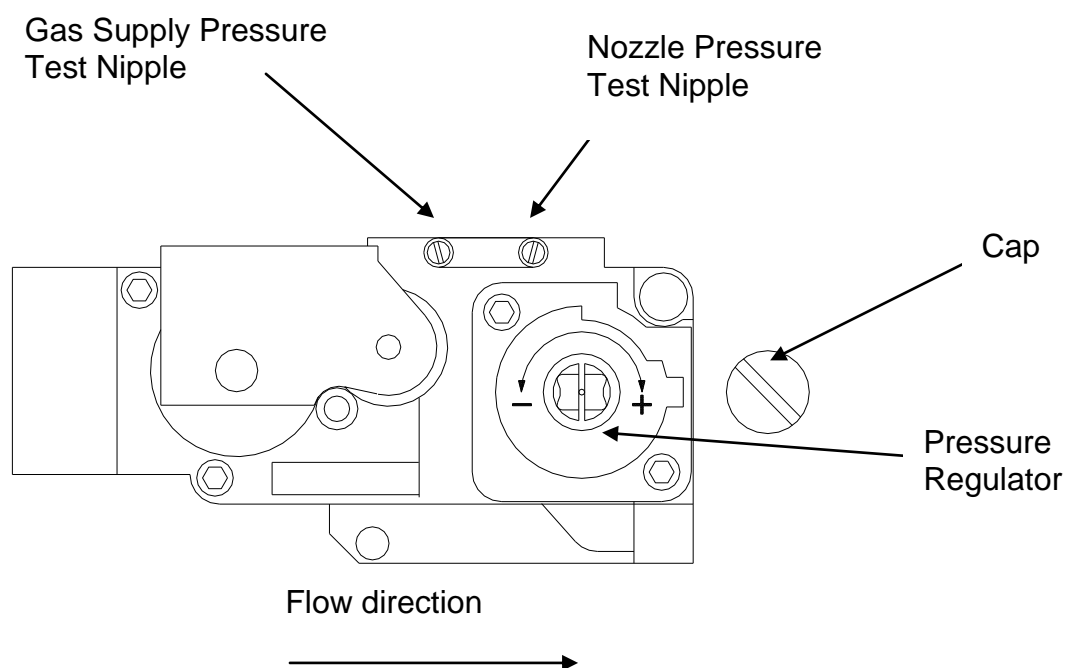

11. Minimum Mounting Height

The minimum heater to ground clearance is four meters. The higher the nominal input load of the heater, the larger need to be the distances to the ground. Applicable local codes and standards regarding minimum mounting height are to be complied with.

According to the German DVGW-Arbeitsblatt 638 Part 1, it is not allowed to expose people to unreasonable amounts of heat. This requirement is considered complied with when the following minimum mounting heights diagrams are respected.

Diagram 1. Minimum Mounting Height for Heaters Mounted at a 45° Angle

Radiant coefficient $\varphi_m = 2,5$ Radiant efficiency 60%
(max. radiant intensity depending on air temperature at $t_g = 17\text{ °C}$, 1.7 m above ground)

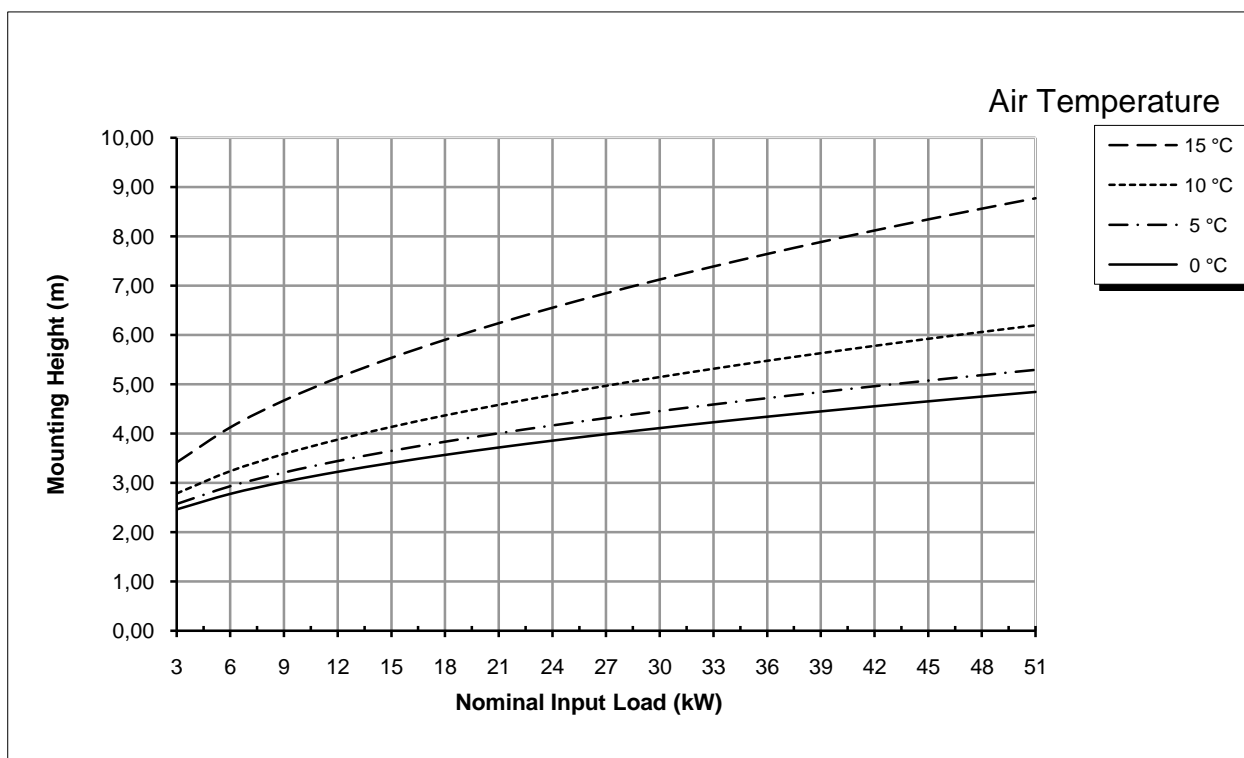

12. Minimum Clearance to Combustibles

In Germany, the distances between heater and combustible materials (situated in directly as well as in indirectly radiated areas) must be large enough to ensure that the surfaces under the heater do not get hotter than 85°C. The allowed distances to combustibles are regulated in Germany in the DVGW 638 Part 1.

Applicable local codes and standards regarding minimum clearance to combustibles are to be complied with.

Should you have any questions or special requirements please contact GoGaS (see cover page).

Diagram 2. Minimum Clearance to Combustibles in Radiated Areas

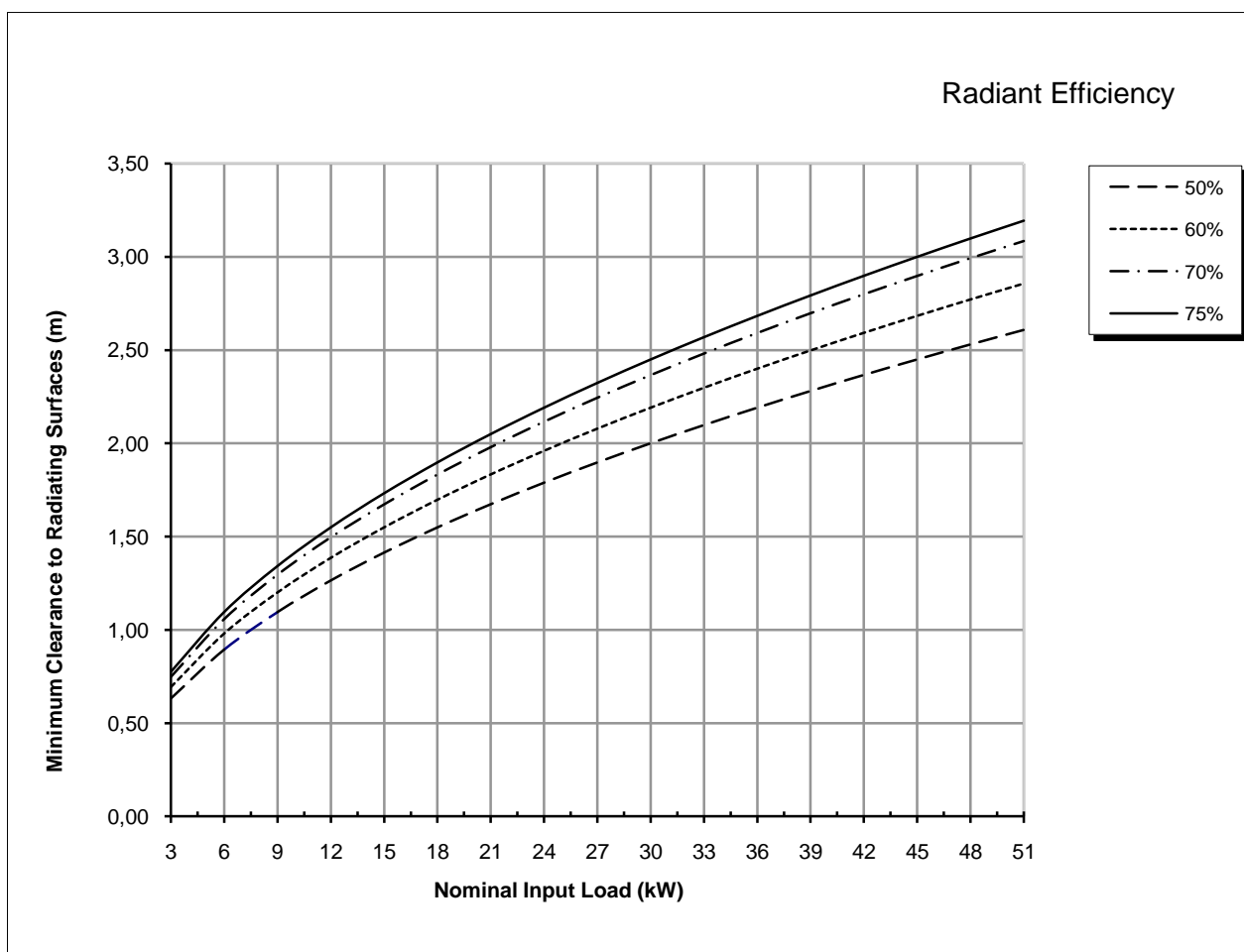

13. Nozzle Pressures Table (Manifold pressures)

VARIOMAX One- or Two Stage High Intensity Heater

Type	Nominal Input Load kW	Gas Type	Min. Supply System Pressure mbar	Manifold Pressure mbar	Nozzle Orifice \varnothing mm	Air Plate \varnothing mm
VARIOMAX 06	3 - 6	Nat. gas G20	20	19,0	2 x 1,30	without
VARIOMAX 12	6 - 12	Nat. gas G20	20	18,8	2 x 1,85	38
VARIOMAX 06	3 - 6	Nat. gas G25	20	19,0	2 x 1,45	25
VARIOMAX 12	6 - 12	Nat. gas G25	20	18,6	2 x 2,00	35
VARIOMAX 06	3 - 6	Propane G31	60	50	2 x 0,80	22
VARIOMAX 12	6 - 12	Propane G31	60	50	2 x 1,10	35

14. Technical Data

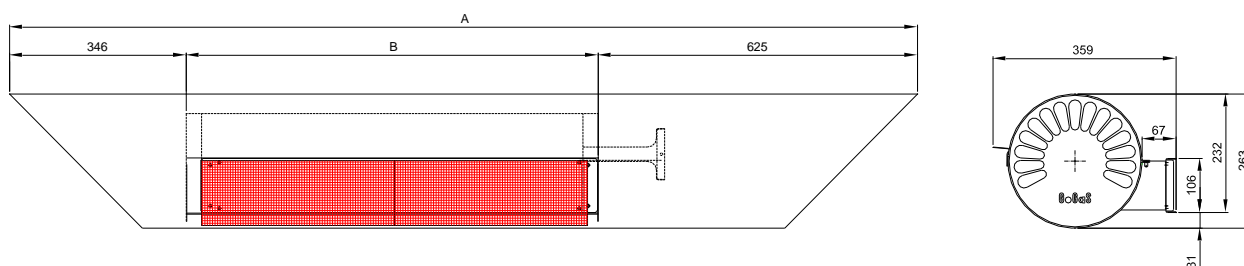

Type	Gas Consumption (Half Load - Full Load)			Dimensions		
	G20 m ³ /h	G25 m ³ /h	G31 kg/h	A mm	B mm	Wt. kg
VARIOMAX 06	0,30 - 0,60	0,35 - 0,70	0,23 - 0,47	1408	438	7
VARIOMAX 12	0,60 - 1,20	0,70 - 1,40	0,47 - 0,93	1778	807	17,5

Nat. Gas G20 ; Hi = 9,97 kWh/m³ ; Ws = 14,89 kWh/m³

Nat. Gas G25 ; Hi = 8,57 kWh/m³ ; Ws = 12,15 kWh/m³

Propane G31 ; Hi = 12,87 kWh/kg ; Ws = 22,55 kWh/m³

Lower Heating Value Hi und Wobbe Index Ws bei 0° C und 1013 mbar

15. Illustration: Connection of the Control Unit

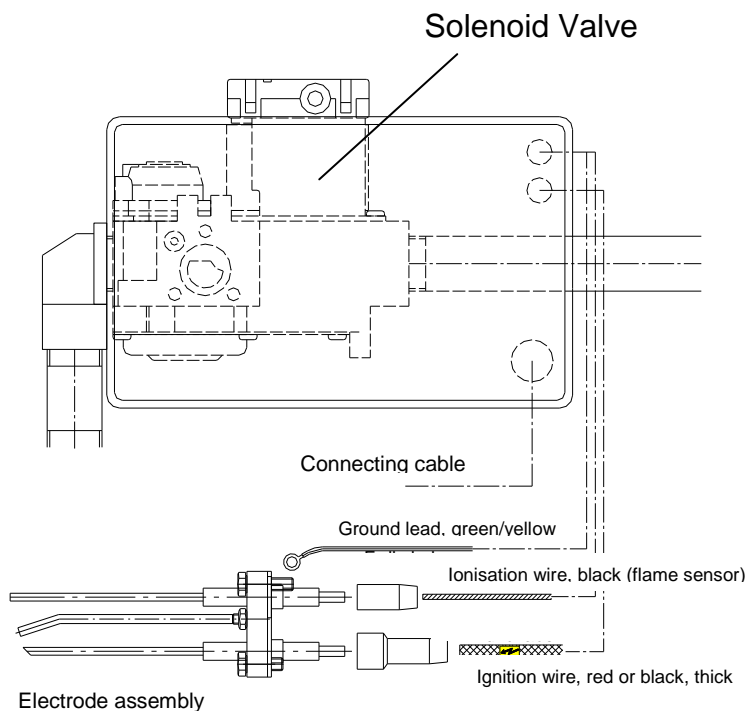

SR 3010-1 (One Stage Layout)

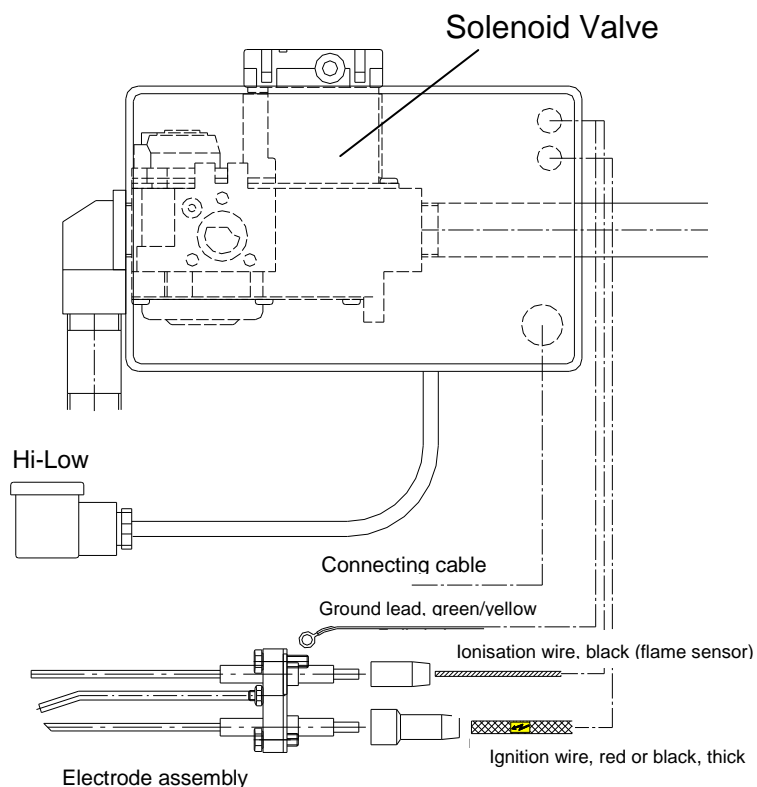

SR 3010-2 (Two Stage Layout)

16. Spare Parts List

GoGaS-Radiant Heater VARIOMAX			Nomina Input Loads	
Item	Description	Art.-Nr.	06	12
1	Combustion chamber N06-Effekt	21206001	1	
2	Combustion chamber N12-Effekt	21206002		1
3	Electrode assembly 01	21001045	1	1
4	Cylinder screw w. slot M5x16	30601015	2	2
5	Hex. nut M5 A2	30604007	2	2
6	Nozzle housing N06-36	32201118	1	1
7	High-low Valve	21004005	1	1
8*	Double nozzle KMI / M	xxxxxxxxx	1	1
9*	Air plate KMI / M	xxxxxxxxx	1	1

* When ordering Items 8 and 9 always specify heater input load and gas type.

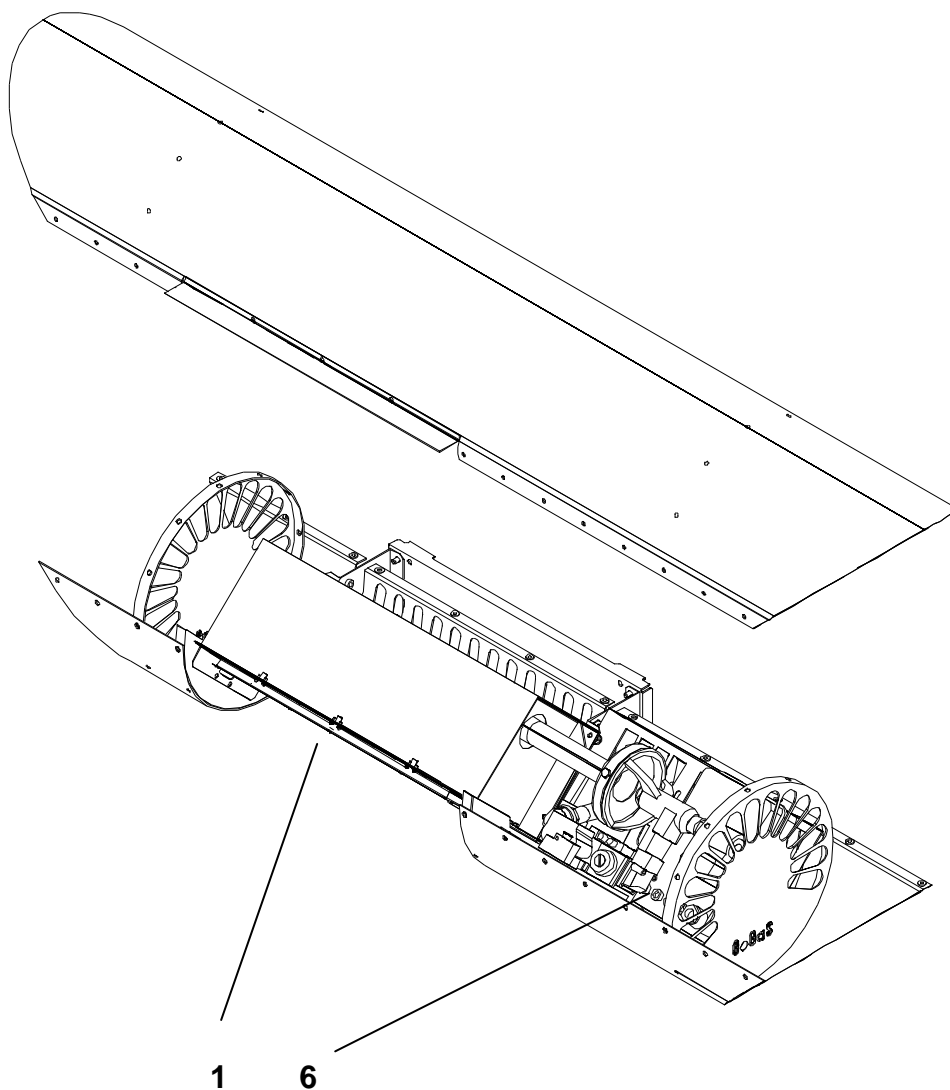

Control unit and gas train			Series SR 3010	
Pos.	Description	Art.-Nr.	single-stage	two-stage
1	Controller SG 300	32001125	1	1
2	Combination valve 1-stage VK 4115	31402087	1	1
3	Connector with cable	31402089	1	1
4	Ignition wire 650 mm lg.	21001046	1	1
5	Cable with connector for 4 mm pin	31902211	1	1
6	Ground lead with extra wire	31901124	1	1
7	Electrode asseby	21001045	1	1
Complete switching and control unit				
	Type SR 3010/ELL-1 stage (G20, G25)	10306140	1	
	Type SR 3010/ELL-2 stage (G20, G25)	10306141		1
	Type SR 3010/P-1 stage (G31)	103061xx	1	
	Type SR 3010/P-2 stage (G31)	103061xx		1

