

# Installation, Operation and Service Instructions

## Series M

(one-stage)	(two-stage)
M 06 - 1	M 06 - 2
M 12 - 1	M 12 - 2
M 18 - 1	M 18 - 2
M 24 - 1	M 24 - 2
M 36 - 1	M 36 - 2

**Read and thoroughly understand these instructions before attempting any installation.**

**Should you have any questions regarding these instructions, please contact:**

**GoGaS Goch GmbH & Co. KG**

**Zum Ihnedieck 18**

**D-44265 Dortmund**

**Germany**

**Tel.: +49 (0)231 46505-0**

**Fax.: +49 (0)231 46505-88**

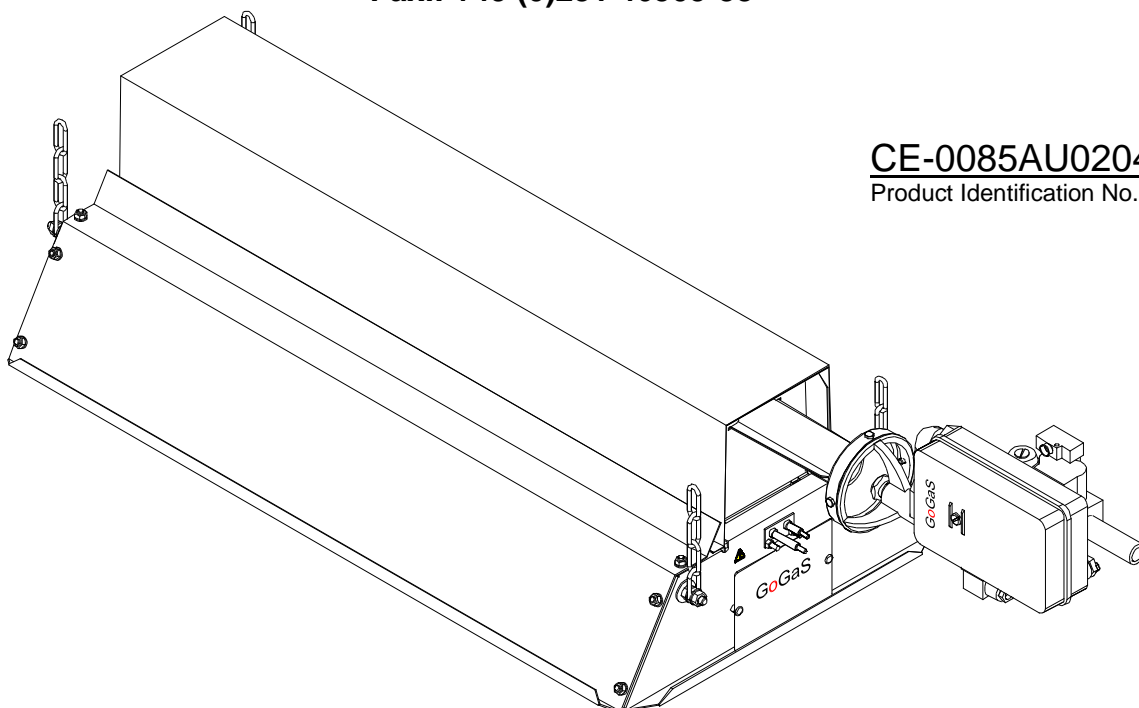

**CE-0085AU0204**

Product Identification No.

# Preface

---

## **Intended Use**

The GoGaS high intensity heater of the series M is intended to be used for the heating of commercial and industrial covered spaces and halls. The appliance must be protected from splash water. An appropriate ventilation of the halls is required, according to local standards and regulations. European standards require a positive air displacement of 10 m<sup>3</sup> per installed kWh.

## **The Technology**

The GoGaS M Series has a stainless steel combustion chamber and comes in ratings from 6 kW to 36 kW. The modern injector burner allows almost pollution-free operation, from the smallest to the largest heater unit. The easy to install reflector is made of highly reflecting material and directs the captured radiation towards the vicinity of persons.

## **Controls**

The M Series can be operated as a one- or a two-stage heater. For two-stage heaters, a double nozzle allows two-stage regulation under constant gas pressure. The gas flow is controlled by changing nozzle orifice size.

*This instructions manual is subject to change without notice.*

# Table of Contents

---

1.	Safety Considerations .....	4
2.	General Information.....	5
3.	Energy supply.....	6
4.	Assembling the Heater .....	6
5.	Installing Nozzle Connecting Piece .....	12
6.	Heater Mounting Instructions .....	13
6.1.	Mounting Heater Type M 36 at an Angle .....	14
7.	Installation of Control unit and gas train SR 3010.....	15
8.	One-stage Heater Startup .....	18
9.	Two-stage Heater Startup .....	19
10.	Troubleshooting.....	21
11.	Service and Maintenance .....	22
12.	Changeover to different gas type .....	24
13.	Setting Nozzle Pressure for One- and Two-Stage Heaters .....	25
14.	Minimum Mounting Height.....	25
15.	Minimum Clearance to Combustibles.....	27
16.	Nozzle Pressures Table .....	28
17.	Technical Data.....	29
18.	Spare Parts List.....	30

## 1. Safety Considerations

---

### Used Symbols

Following warning icons are used to indicate hazards:



Warning - failure to comply may result in personal injury and property damage.



Warning about working with electrical equipment.

**Only the manufacturer or an approved installing or service company are allowed to perform work on this heater, complying with the local standards. This heater must be installed and serviced only by the manufacturer or by personnel, who have been trained, qualified and understand all applicable codes. In Germany, only the manufacturer or an approved installing or service company are allowed to perform work on this heater, complying with the DVGW-Arbeitsblatt G 676.**



**This appliance must be installed in accordance with current connection and installation regulations and may only be used in adequately ventilated rooms. The installation and operating instructions must be thoroughly read and understood before installation, startup and service.**



**Before installation it must be checked if local gas distribution, gas type, gas pressure and the settings of the appliance are compatible with each other.**

## **2. General Information**

---

GoGaS infrared heaters are manufactured in accordance with DIN EN 419. Each appliance is subjected to a function test before it leaves the factory and is preset to the relevant gas type. When installing and operating radiant heaters, the local regulations and guidelines must be complied with. In Germany, these are:

Aufstellung von Strahlungsheizungsanlagen ( <i>Installing Radiant Heating Systems</i> )	DVGW Arbeitsblatt G 638/I
Technische Regel für Gasinstallation ( <i>Technical Rules for Gas Installations</i> )	DVGW Arbeitsblatt G 600 TRGI 1986/96
Technische Regel Flüssiggas ( <i>Technical Rules for Liquid Gas</i> )	TRF 1996
Technische Regel für die mechanische Abführung der Abgase von Feuerstätten ( <i>Technical Rules for Mechanical Elimination of Heating System Flue Gas</i> )	DVGW G 660
Regeln für Berechnung des Wärmebedarfes von Gebäuden ( <i>Rules for Calculating Heat Load for Buildings</i> )	DIN 4701
Sicherheits-technische Ausrüstung von Heizungsanlagen ( <i>Safety-related Equipment for Heating Systems</i> )	DIN 4751
Gasfeuerungen in Heizungsanlagen ( <i>Gas Firing Equipment in Heating Systems</i> )	DIN 4756
Bestimmungen für das Errichten von Starkstromanlagen ( <i>Regulations for High Voltage Systems Installation</i> )	VDE 0100
Allgemeine Anforderung für die elektr. Sicherheit ( <i>General Requirements for Electrical Safety</i> )	VDE 0702
Technische Anschlussbedingungen Der örtlichen Energieversorgungs- Unternehmen ( <i>Technical Requirements of the Local Power Supply Company</i> )	TAB
Landesbauordnung ( <i>Regional Building Regulations</i> )	LBO
Feuerungsverordnung der Länder ( <i>Regional Firing Installations Regulations</i> )	FeuVO

### 3. Energy supply

---

**Gas connection:** R ½ male thread

Connection	Gas supply line pressures	
	Maximum	Minimum
Nat. gas G20	100 mbar	20 mbar
Nat. gas G25	100 mbar	20 mbar
Propane G31	100 mbar	55 mbar

**Gas consumption:** see Ch. 17 Technical Data

#### Electrical connection

Alternating current AC Voltage 230 V, 50Hz with L, N and PE

**Power consumption:** 12 W for one-stage heaters  
32 W for two-stage heaters

### 4. Assembling the Heater

---



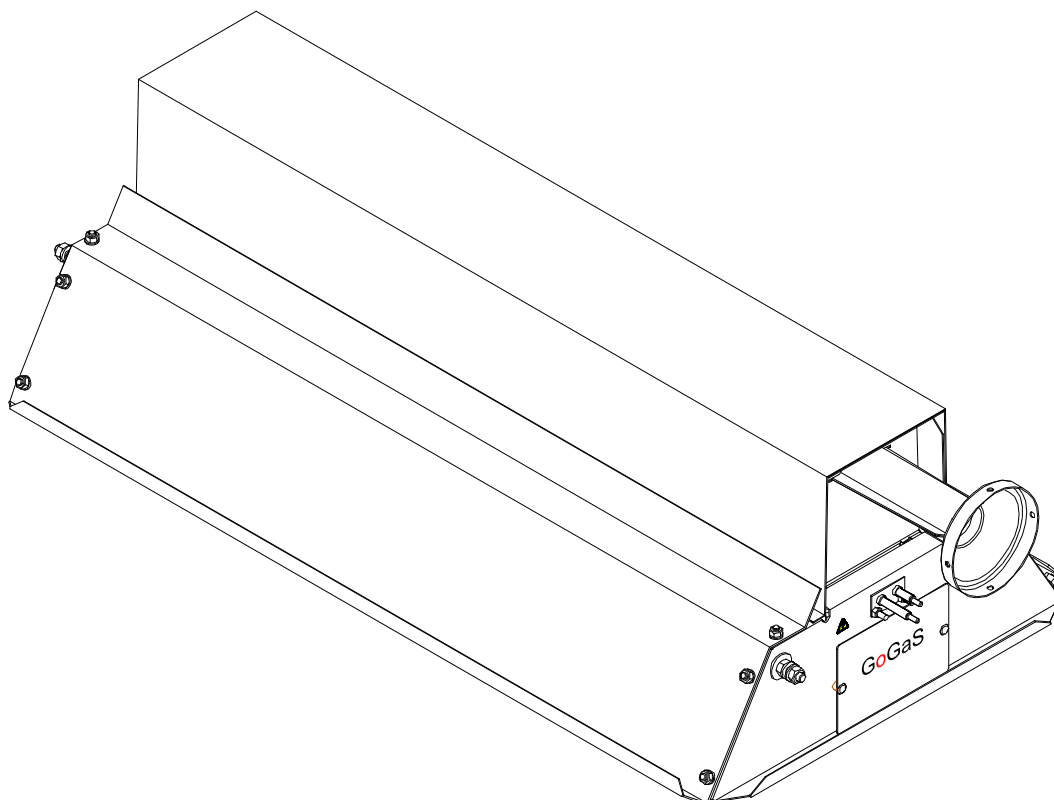



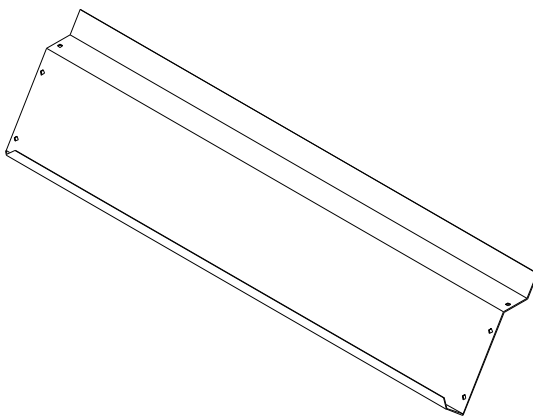
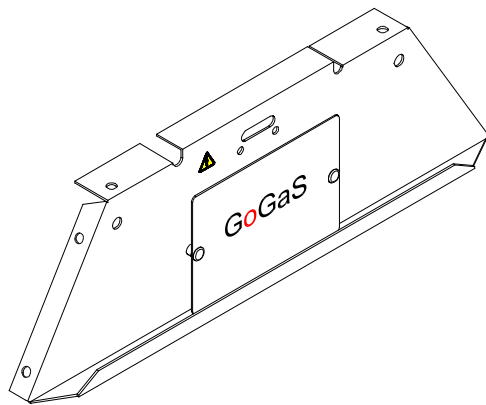
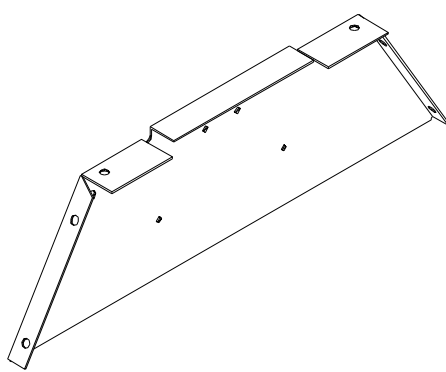
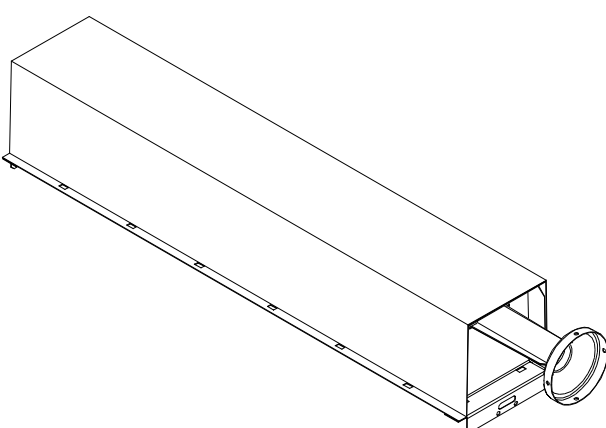
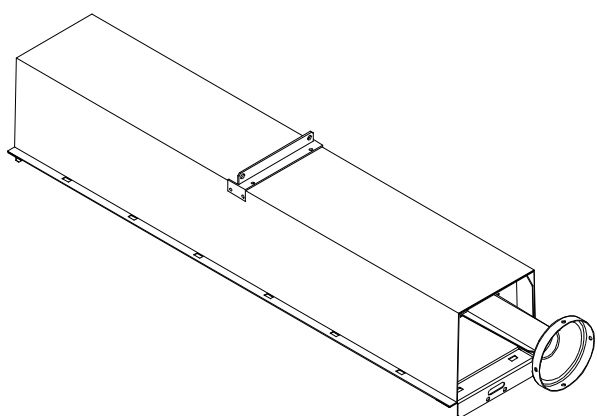
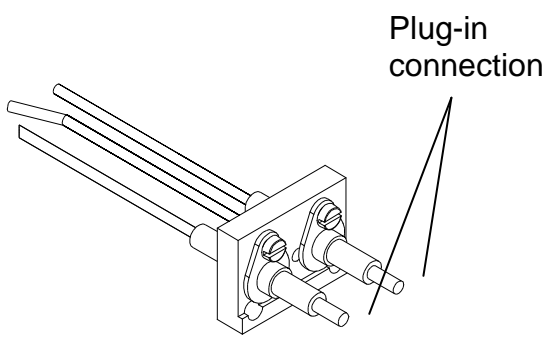



The GoGaS Series M high intensity heater is delivered in individual components and must be assembled prior to mounting. The following pages contain the assembly instructions.



## Components

<p><b>Item 1</b></p>  <p>2 x Long reflector M 06-36</p>	<p><b>Item 2</b></p>  <p>1 x Front reflector M 06-36 with rating plate</p>
<p><b>Item 3</b></p>  <p>1 x Front reflector M 06-36 without rating plate</p>	<p><b>Item 4</b></p>  <p>1 x Combustion chamber N 06-24</p>
<p><b>Item 4.1</b></p>  <p>1 x Combustion chamber N 36 with 1 Angled mounting kit – M 36 Middle -</p>	<p><b>Item 5.</b></p>  <p>1 x Electrode assembly</p>

## Connection Elements

Item	Qty.	Description	Size	DIN / EN	Illustration
6	12 Pcs.	Hexagonal screw	M 6 x 12	24017	
7	12 Pcs.	Hexagonal nut	M 6	24034	
8	12 Pcs.	Washer	6,4	125	
9.1	2 Pcs.	Cylinder screw with slot	M 5 x 16	1207	
9.2	1 Pcs.	Hexagonal screw	M 5 x 16	24017	
9.3	1 Pcs.	Hexagonal screw	M 5 x 20	24017	
10	3 Pcs.	Hexagonal nut	M 5	24034	
11	4 Pcs.	Hexagonal screw	M 8 x 30	24017	
12	8 Pcs.	Washer	8,4	9021	
13	8 Pcs.	Hexagonal screw	M 8	24034	
14	8 Pcs.	Washer	8,4	125	

## Illustrated Assembly Instructions

### 1. Pre-assembly

Front reflector  
with rating plate (2)

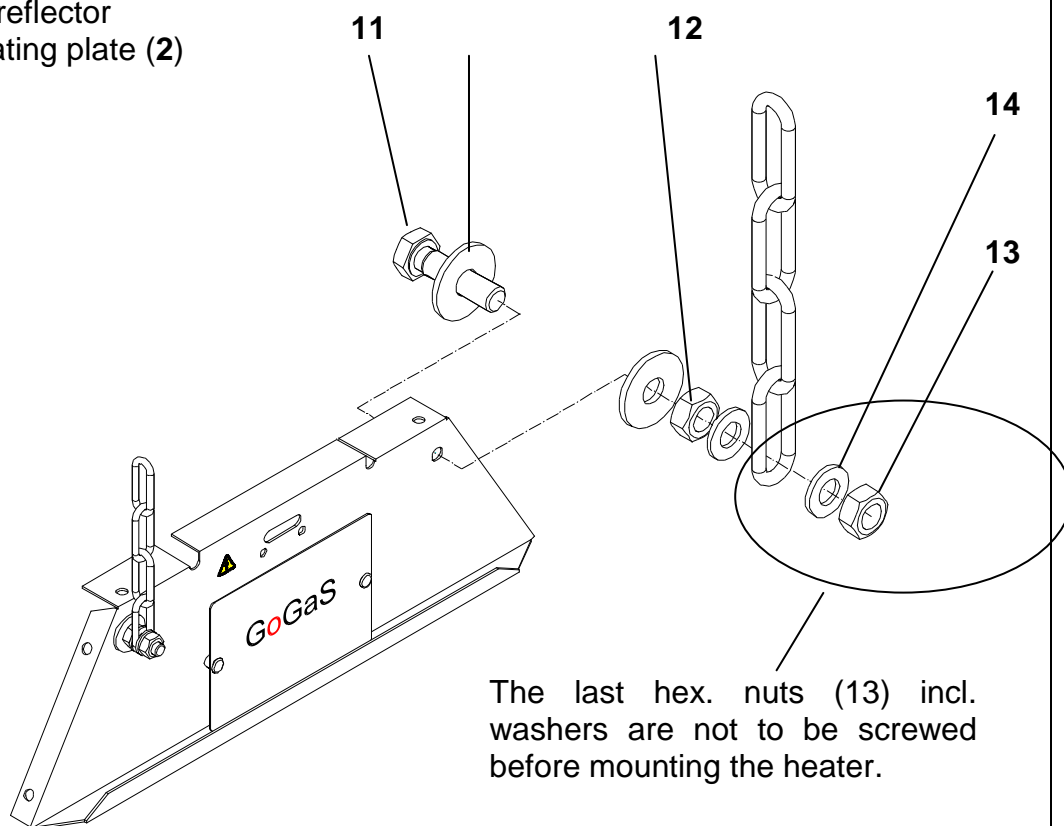

### 2. Pre-assembly

Front reflector (3)

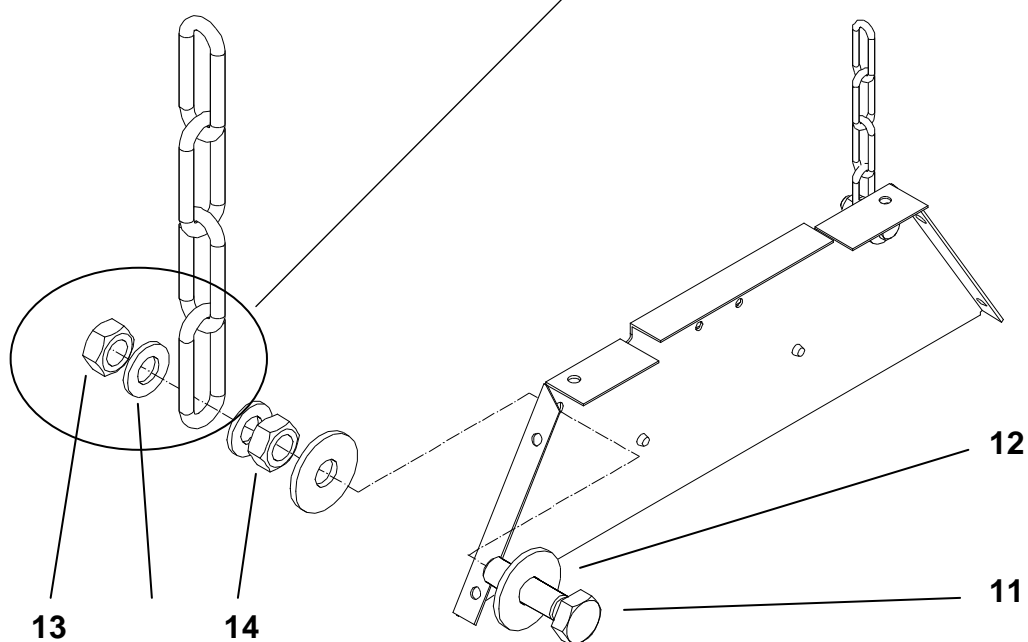

3. Lay combustion chamber with the ceramic tiles facing upwards.

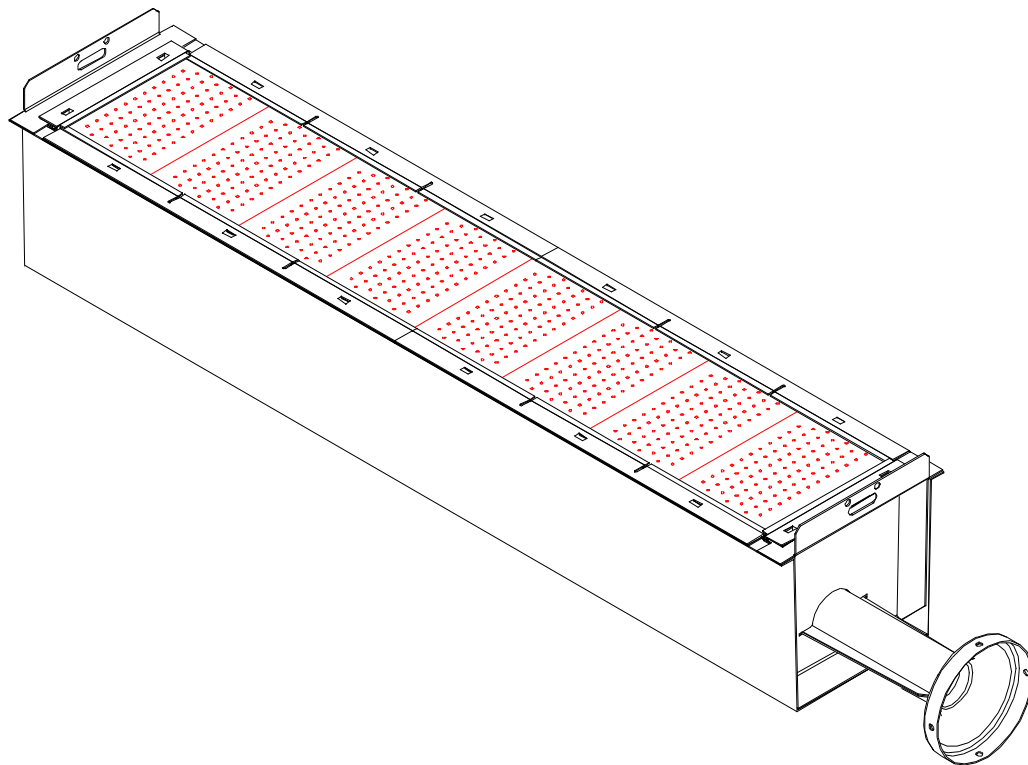

4. Fasten front reflector with rating plate (2) and electrode assembly (5) with screws (9.2,9.3) and nuts (10).

**Attention!** Screw heads must face inwards.

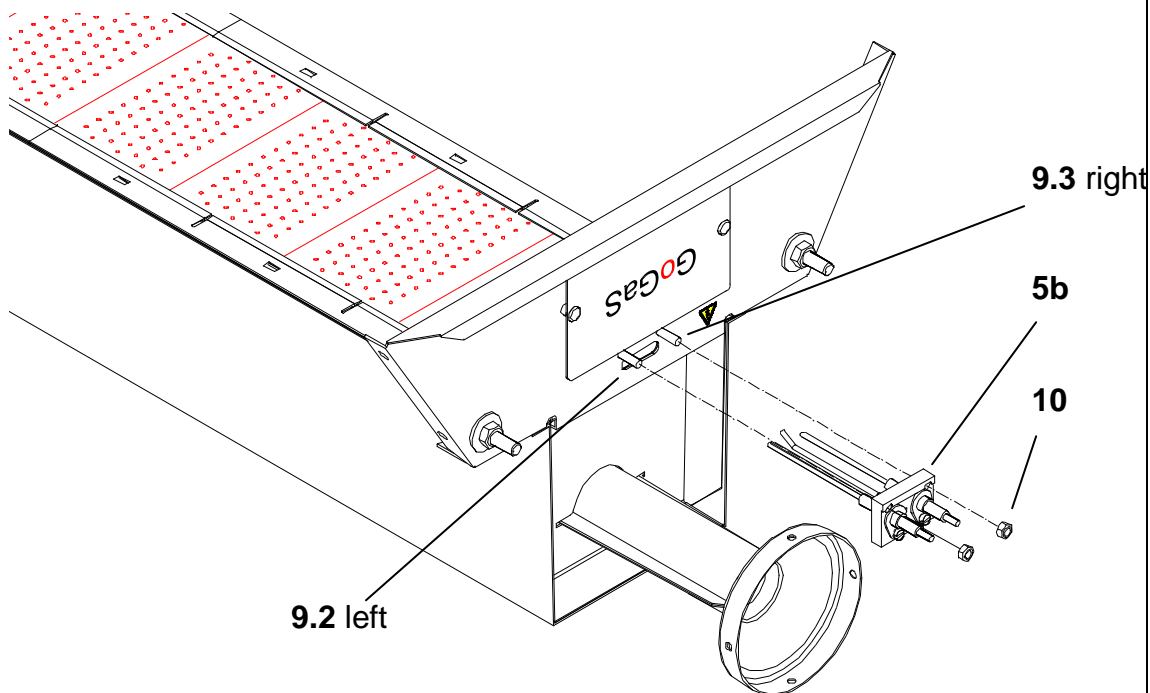

**Attention!** Screw (9.2) to the left!

5. Pre-assembly long reflector (1) with front reflector (3).  
**Attention!** Screw heads must face inwards.

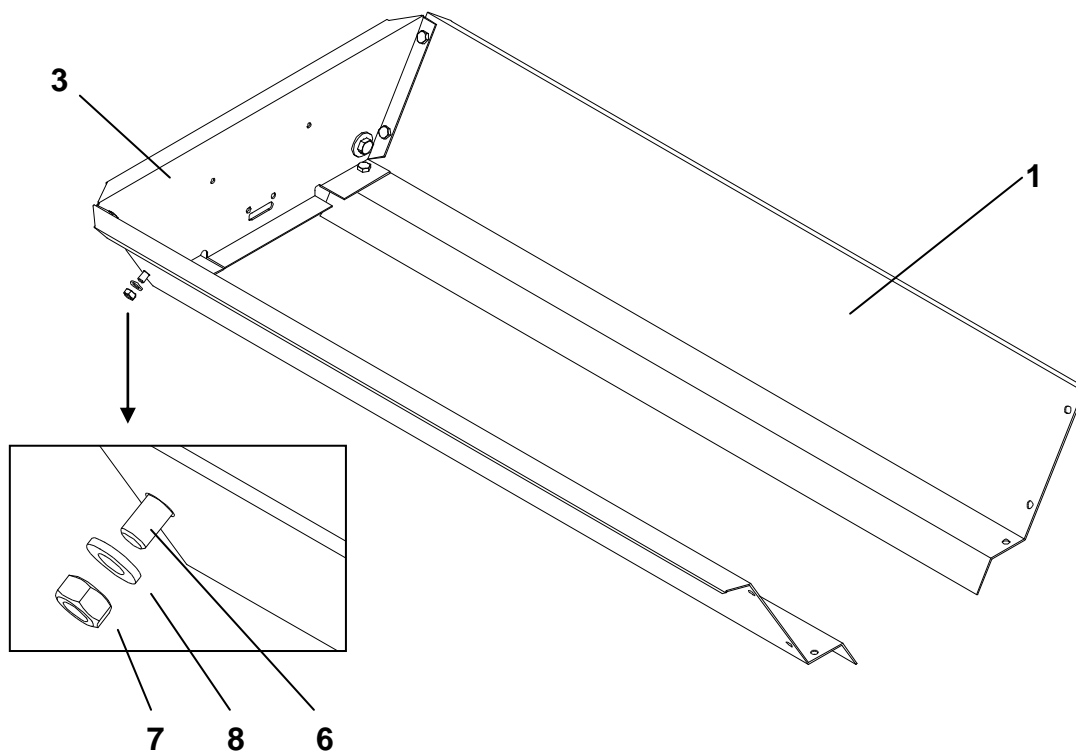

6. Put pre-assembled reflector parts on the Combustion chamber and screw to Front reflector with rating plate (2).  
**Attention!** Screw heads must face inwards.

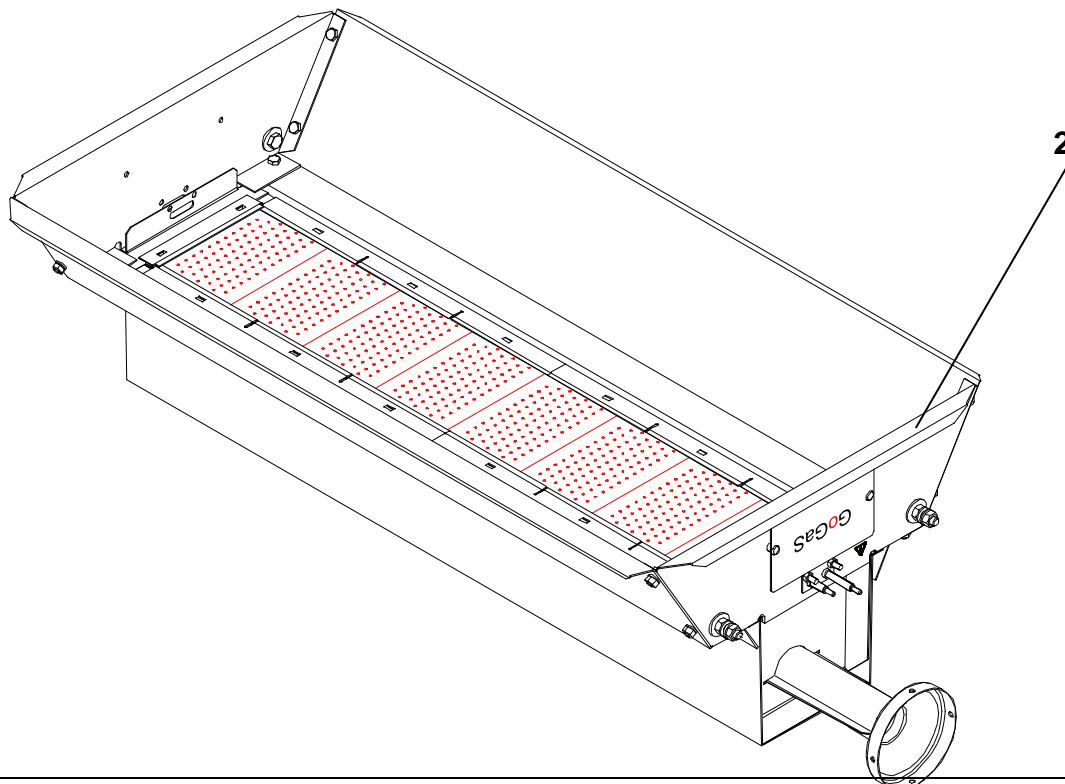

## 5. Installing Nozzle Connecting Piece

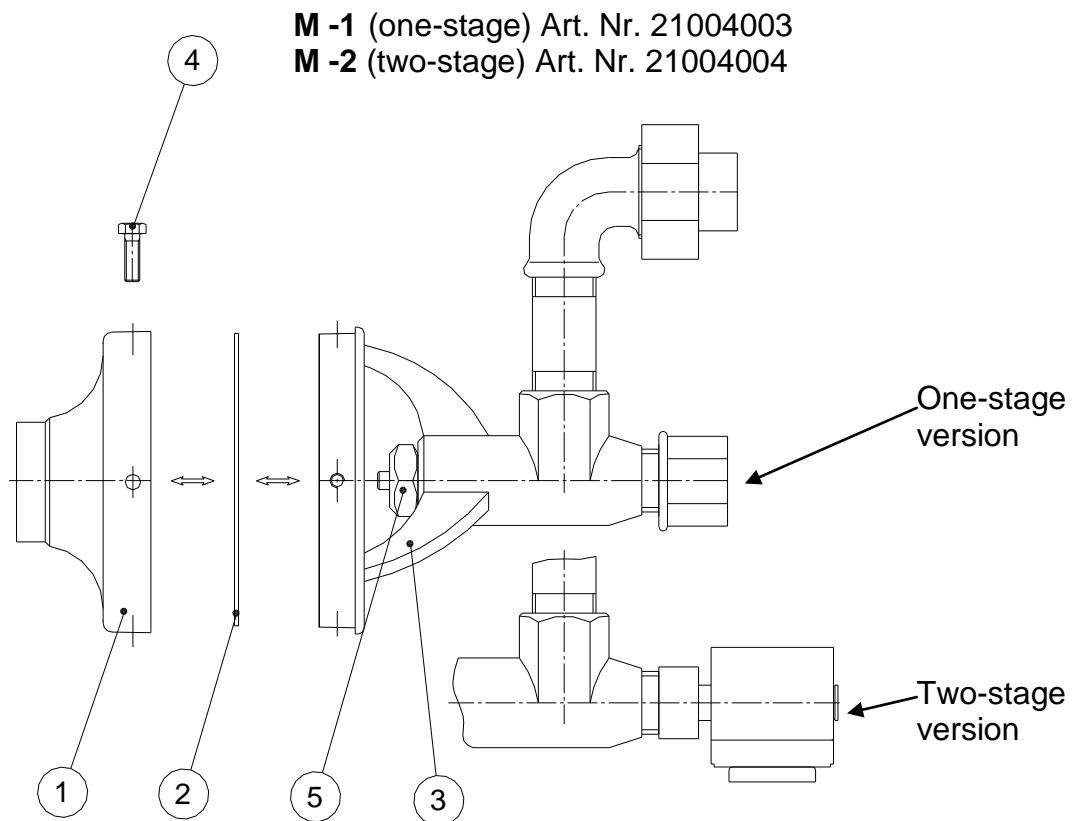

Before mounting the nozzle connecting piece on the venture neck, the air plate **(2)** and nozzle orifice **(5)** sizes must be compared with the rating plate specifications.

Procedure:

- Remove the securing clips (not shown) from the venture neck (note: some infrared heaters do not have any air plates and therefore no securing clips).
- Push the orifice housing **(3)** into the venture neck **(1)** and screw it tight using the four M5 screws **(4)** provided.

## 6. Heater Mounting Instructions

GoGaS High Intensity Heaters are approved to be operated horizontally and at a maximum of 45° inclined angle (mounting kit AW 84/II, Fig. Heater Mounting). Other mounting angles are not allowed. Only mounting kits provided by GoGaS are allowed for use. Screws and wall plugs are not included. Do not use plastic wall plugs for mounting! Use mounting points located on the heater for installation (see Fig. Heater Mounting)

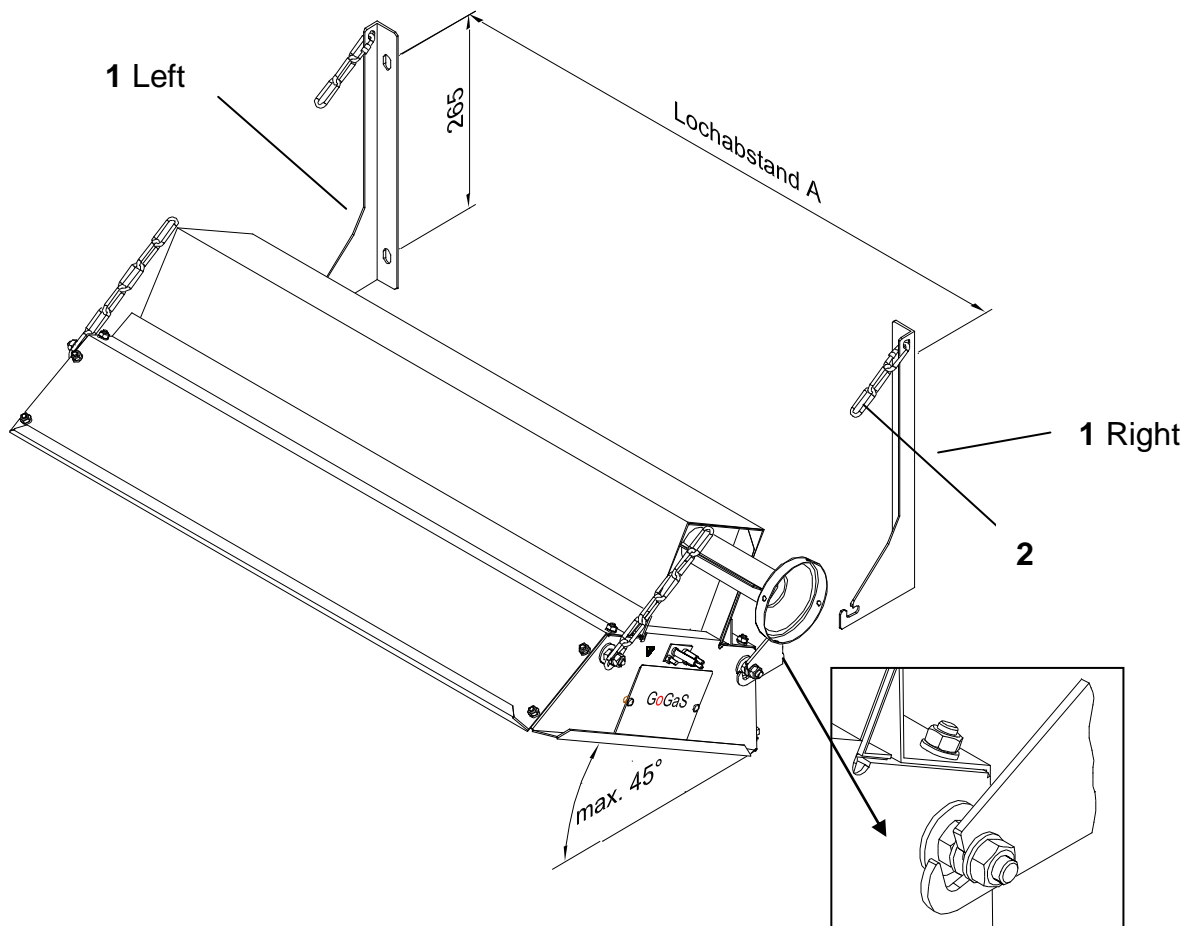

**Fig. Heater Mounting**

Item.	Qty.	Description	Type
1	1 set	Angled mounting kit	AW 84/II
2	1 set	Accessories	AW 84/II
3	1 set	Angled mounting kit - M 36 Middle -	

Type	M 6	M 12	M 18	M 24	M 36
Hole spacing A (mm)	447	816	1185	1554	2295
Weight (kg)	7	13	17	22	31



The Angled mounting kit for heater type M 36 needs an additional mounting part.

## Mounting Heater Type M 36 at an Angle

For safety reasons, the combustion chamber must be suspended from the middle as well.

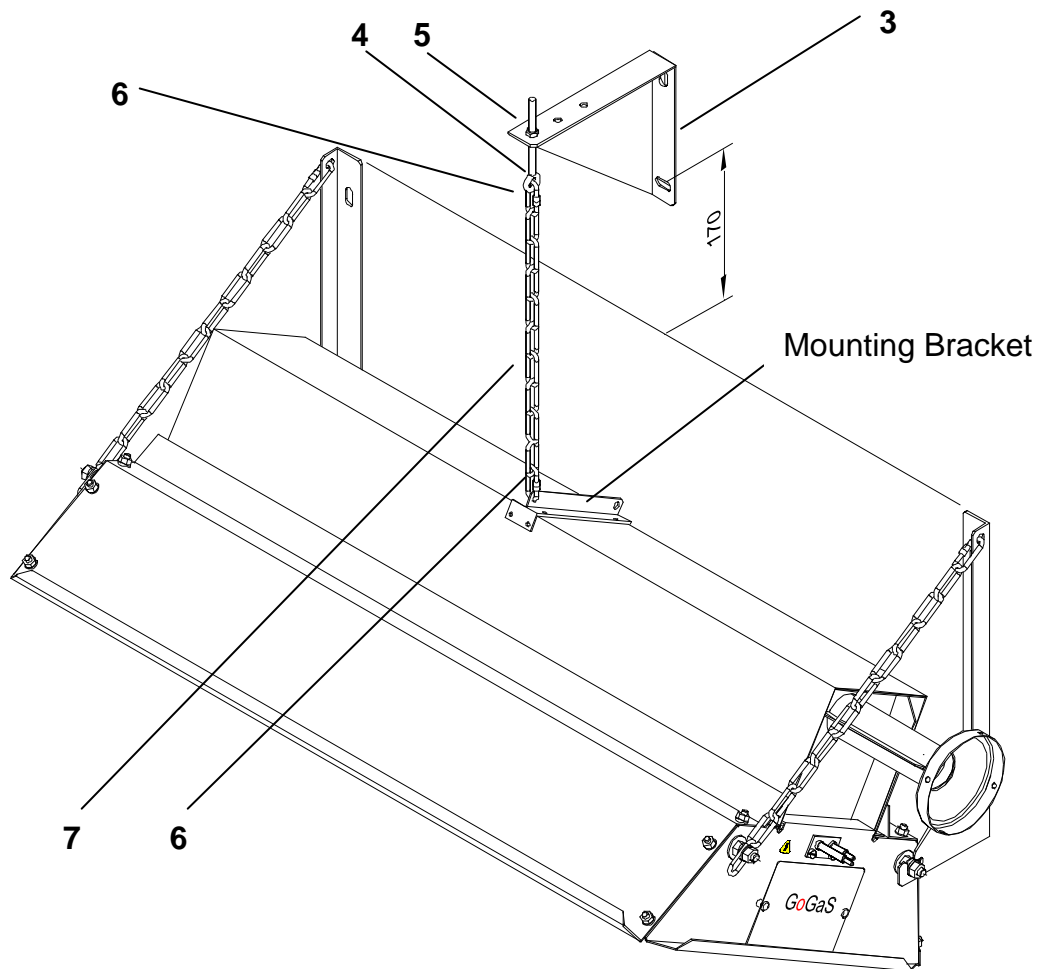

For this purpose, an additional mounting bracket is included in the delivery of the M 36 heater.

- Position the bracket **(3)** on the wall as illustrated (do not use any plastic wall plugs!).
- Attach chain fastener **(7)** to ends of chain **(6)**. Attach chain on one end to the bracket on the combustion chamber and on the other end to eye bolt **(4)**. Insert eye bolt **(4)** through one of the 3 holes on the bracket **(3)**.



If possible, choose the hole in such a way that the chain hangs perpendicular to ground.

- Screw the self-locking hex. nut **(5)** on the eye bolt **(4)** until the chain is straight.



Do not generate any tension in the chain.

## 7. Installation of Control Unit and Gas Train SR 3010

---



For your safety, shut off the main gas valve, and disconnect all electrical supply to the High Intensity Unit.

### Control Unit and Gas Train SR 3010

- Tighten the screw connection **(1)** to attach the control unit and gas train.



The solenoid and the combination valve are to be installed in the upright position or at max. 90° angle to the screw axes **(1)** and **(2)** (see Fig. 1 and 2)

### Connecting Spark Igniter and Ionization Flame Monitoring (Electrode Assembly)



Do **NOT** connect ignition wire, flame sensor wire and ground lead to each other.



The flame sensor wire is marked with the following sign  on the heater body.

- Attach porcelain connector to the igniter wire
- Attach porcelain connector to flame sensor wire
- Tighten ground lead with hex nut
- **For two-stage heaters:** screw the connector **(4)** to solenoid gas valve

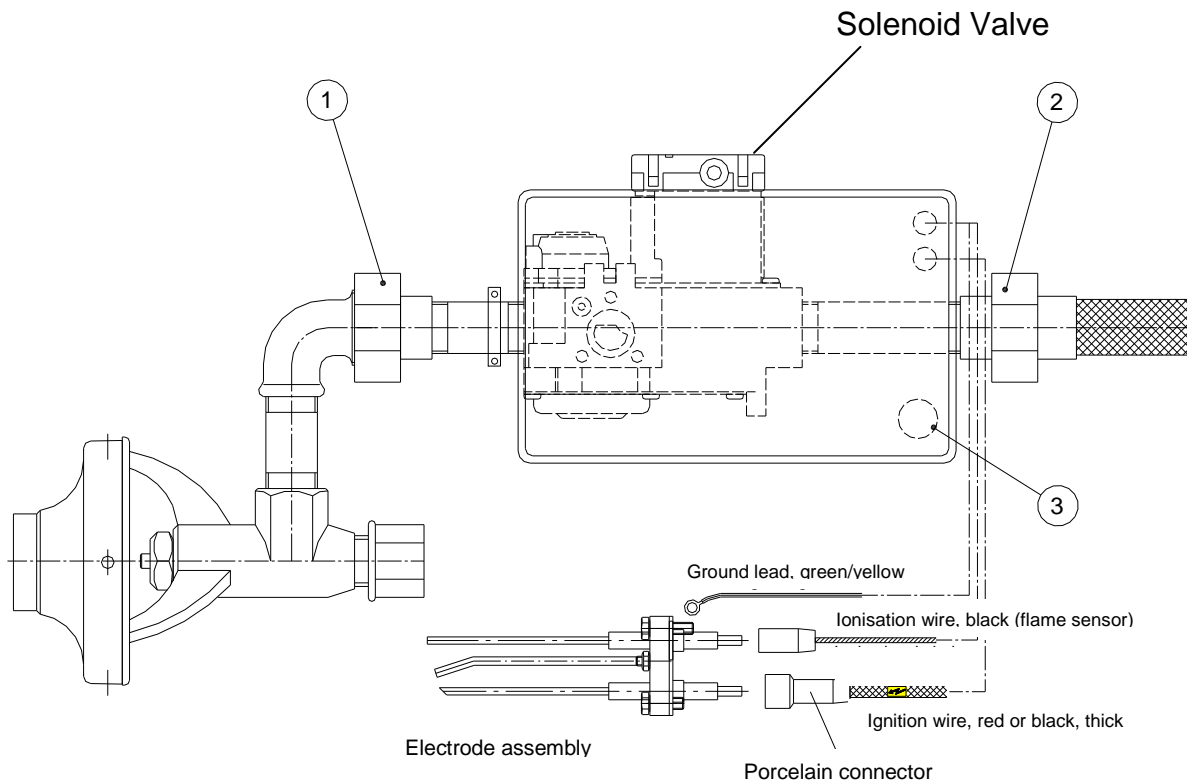

**Fig 1. SR 3010-1 (One Stage Layout)**

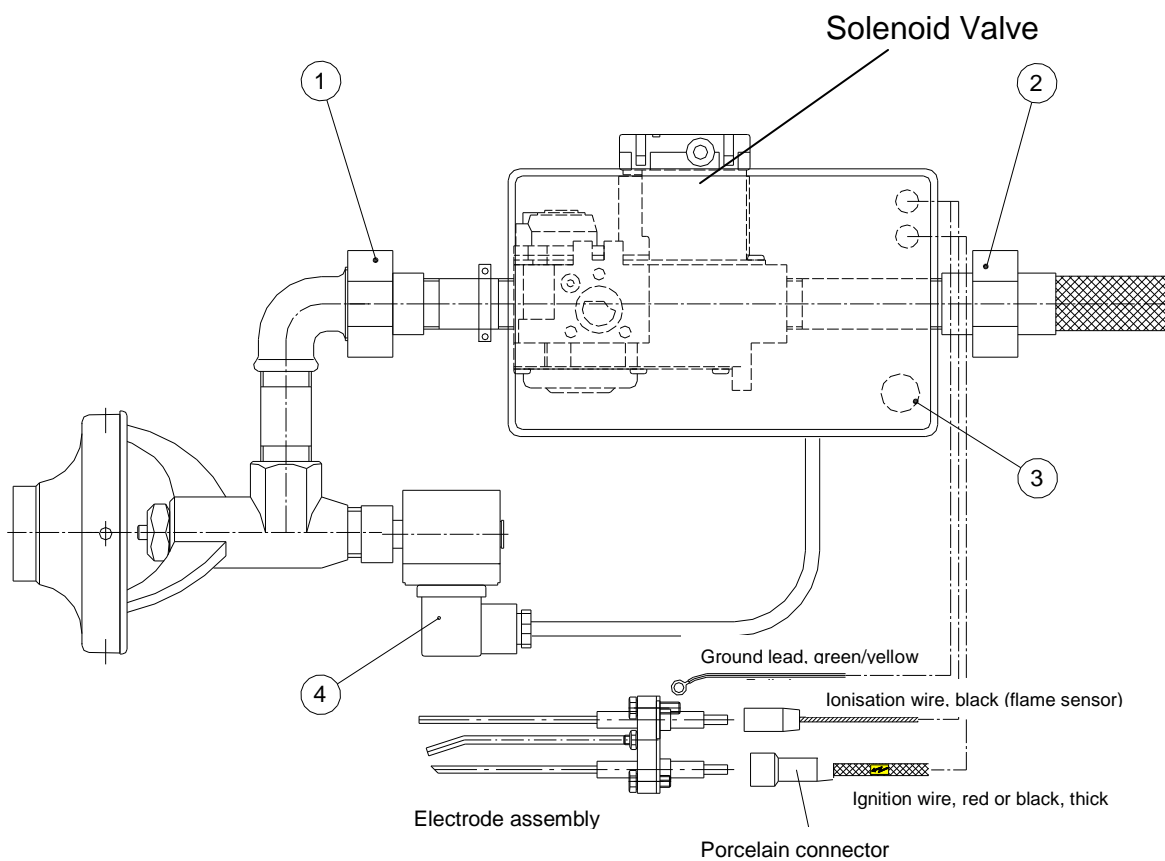



**Fig. 2. SR 3010-2 (Two-Stage Layout)**

## Gas Connections

The gas connection is made using a Flexible Gas Connector. Connect the ball valve train assembly to the gas line in front of the control system and close the ball valve.

 Flexible connector should not be under tension when connected to the heater (refer to illustration below)

 It is recommended to test leak the system before connecting the heater to control system as the leak test may damage the combination valve.

 The solenoid and the combination valve are to be installed in the upright position or at max. 90° angle to the screw axes **(1)** and **(2)** (see Fig. 1 and 2).

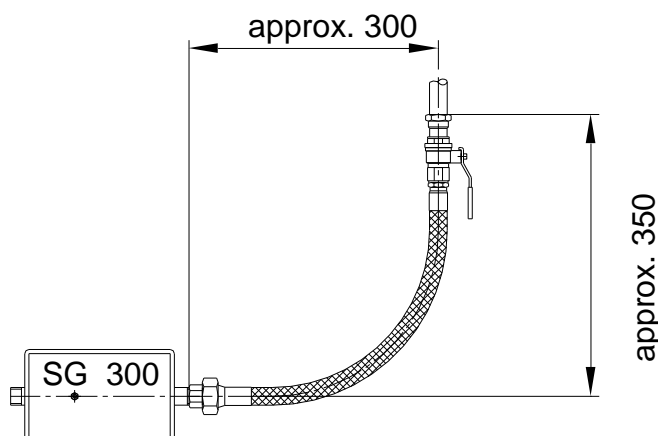

## One-Stage Electrical Connection

- Insert electrical supply wiring through the cable gland **(3)** of the controller and connect to the L1, N and ground terminal.
- The control unit and gas train is designed for an input voltage of 230 V, 50 Hz alternating current with ground lead and operates in the VDE<sup>1</sup>-approved tolerance range of -15% to +10%. Power consumption 12 W. Input voltage to be checked before startup.

 Ensure correct polarity of electric connection. Make sure to ground the system.

## Two-Stage Electrical Connection

- Insert the four-wire cable through the cable gland **(3)** of the controller and connect the L1, N, PE and the two-stage switching wire to terminal 4.

<sup>1</sup> Verband Deutscher Elektrotechniker

## 8. One-stage Heater Startup

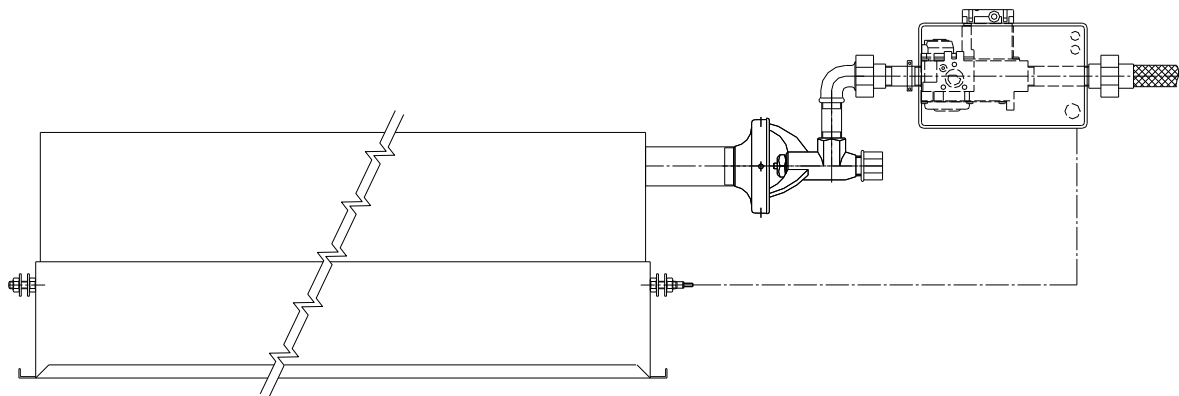

### a) Checking Gas Supply Pressure

Open the manual gas valve and measure the gas supply line pressure at the test nipple (See Fig. Combination Valve - Top View). The connected gas supply pressure must comply with the specifications in Ch. 3 Energy Supply, otherwise the startup must be interrupted.

In case of appropriate gas supply pressure, the heater may be turned on using the respective switching system (either switchbox or switching- and control system).



Measure the gas supply pressure again during full load operation. If the gas pressure is too low, the operation must be interrupted. After measurement, close gas pressure test nipple.

### b) Operating Sequence of the SG 300 Controller

- Connect electricity to unit.
  - 1.5 sec after switching on, the igniter creates a high-voltage spark and, simultaneously, the solenoid gas valve opens.
    - If after an ignition attempt of max. 30 sec. no flame is recognized by the ionization flame monitoring module, the ignition stops and the gas valve closes (the heater shuts down for safety and sends a failure report).
    - If during the ignition attempt (max. 30 sec.) a flame appears and creates an ionization current  $\geq 0.8\mu\text{A}$ , the ignition stops and the unit remains in operation.
- Reset after safety shutdown
  - The heater needs to be disconnected for at least 5 sec. Afterwards repeat ignition as described above.
- Reigniting

- If a malfunction occurs during operation, the igniter will automatically turn on for a maximum duration of 30 sec. If no ionization current is recognized within this ignition attempt period, the heater goes into safety shutdown.

### c) Checking Nozzle Pressure

- Connect pressure measuring device to nozzle test nipple (see Fig. Combination Valve - Top View)
- Turn on heater
- Compare measured nozzle pressure to rating plate specifications. If necessary, use pressure regulator to correct. For correct nozzle pressures refer to Table in Ch. 16.

### d) Leak-Test

- Perform leak-test for all gas-carrying components (from ball valve gas connector to nozzle) during heater operation.

## 9. Two-stage Heater Startup

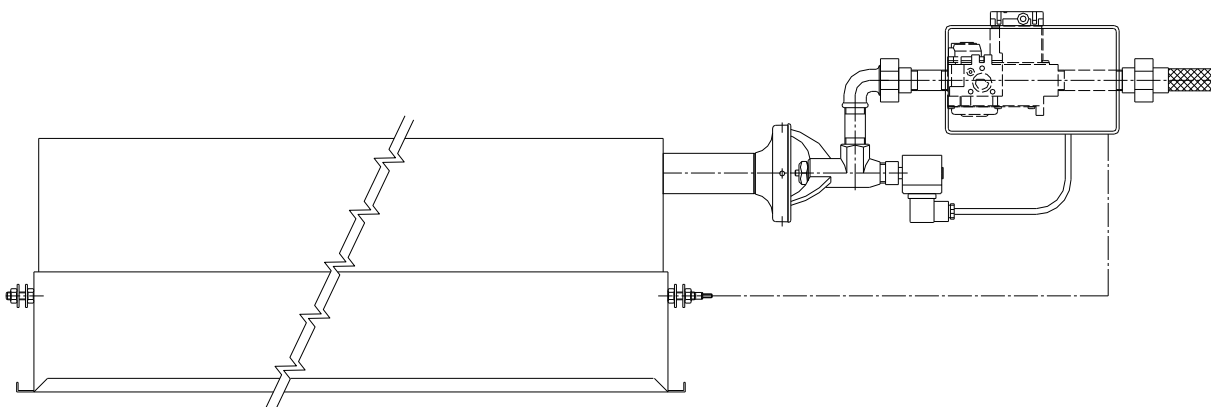

For the two-stage heaters of the Series M and KMI, the power control is not performed through conventional pressure level changing. It is performed by means of a **double nozzle with High-low valve** which allows two-stage regulation under constant gas pressure. The input load is controlled by changing nozzle orifice size. At full load, the two nozzle orifices are open. At half load, an electrically operated rod closes one of the orifices. In this position the heater receives only 50% of the nominal input load.

### a) Checking Gas Supply Pressure

Open the manual gas valve and measure the gas supply line pressure at the test socket. The connected gas supply pressure must comply with the specifications in Ch. 3 Energy Supply, otherwise the startup must be interrupted.

In case of appropriate gas supply pressure, the heater may be turned on using the respective switching system (either switchbox or switching- and control system).



Measure the gas supply pressure again during full load operation. If the gas pressure is too low, the operation must be interrupted. After measurement, close gas pressure test nipple.

### **b) Operating Sequence of the SG 300 Controller and Two-Stage Operation**

- Connect electricity to unit.  
The voltage applied to the solenoid valve turns the heater on at full load.



The heater switches on correctly only at full load.

- 1.5 sec after switching on, the igniter creates a high-voltage spark and, simultaneously, the solenoid gas valve opens.
  - If after an ignition attempt of max. 30 sec. no flame is recognized by the ionization flame monitoring module, the ignition stops and the gas valve closes (the heater shuts down for safety and sends a failure report).
  - If during the ignition attempt (max. 30 sec.) a flame appears and creates an ionization current  $\geq 0.8\mu\text{A}$ , the ignition stops and the unit remains in operation.
- Reset after safety shutdown
  - The heater needs to be disconnected for at least 5 sec. Afterwards repeat ignition as described above.
- Reigniting
  - If a malfunction occurs during operation, the igniter will turn on for a maximum duration of 30 sec. If no ionization current is recognized within this ignition attempt period, the heater goes into safety shutdown.

### **c) Checking Nozzle Pressure**

- Connect pressure measuring device to nozzle test nipple (see Fig. Combination Valve - Top View)



Switch heater on at full load

- Compare measured nozzle pressure to rating plate specifications. If necessary, use pressure regulator to correct. For correct nozzle pressures refer to Table in Ch. 16.

### **d) Testing Two-Stage Operation**

- Switch on heater at full load and allow 10 to 15 min. to burn until the ceramic tiles glow brightly.
- Switch heater to half load and allow 10 to 15 min to burn. The ceramic tiles will turn considerably darker.
- Switch back to full load.

### e) Leak-Test

- Perform leak-test for all gas-carrying components (from ball valve gas connector to nozzle) during heater operation.

## 10. Troubleshooting

Symptom	Possible cause
No spark, no ignition.	<ul style="list-style-type: none"> <li>• No power to control unit</li> <li>• Controller defective</li> <li>• Spark electrode defective</li> <li>• Ignition wire defective or loose</li> </ul>
Heater sparks but will not light.	<ul style="list-style-type: none"> <li>• No gas supply</li> <li>• Combination valve will not open</li> <li>• Check nozzle pressure</li> <li>• Nozzle is dirty or clogged</li> </ul> <p><b>Just in case of two-stage heaters:</b></p> <ul style="list-style-type: none"> <li>• High-low valve is stuck</li> <li>• High.low solenoid defective</li> </ul>
Heater lights but locks out after about 30 sec.	<ul style="list-style-type: none"> <li>• Reverse polarity on electric supply</li> <li>• Flame monitoring sensor (ionization electrode) defective</li> <li>• Flame sensor wire defective or loose</li> <li>• Control unit defective</li> </ul>
Heater lights for several minutes but then shuts down. After repeated ignition it remains in operation.	<ul style="list-style-type: none"> <li>• Flame monitoring sensor (ionization electrode) damaged</li> </ul>
Heater back-fires.	<ul style="list-style-type: none"> <li>• Ceramic tiles damaged</li> <li>• Sealing of the ceramic tile to the burner body damaged</li> </ul>

## 11. Service and Maintenance

---

### Warning



**Before servicing and maintenance make sure to close the gas valve and cut electrical power to the heater off. The heater must be de-energized and secured against switching on!**

Infrared heaters are to be serviced at least once per year according to local codes. In Germany, these are DIN 4756 and DVGW-Arbeitsblatt G 638/I.

To ensure a safe, economical and stable operation, the operator of the radiant heating system should allow the performing of inspection and service by the power utility company, by the manufacturer of the system or by approved installation companies.

This heater must be serviced only by a trained gas service technician. Only personnel who have been trained and understand all applicable codes should undertake the service.

This heater must be serviced only by a trained gas service technician. Only personnel who have been trained and understand all applicable codes should undertake the service.

Particularly following tasks have to be completed during the inspection and maintenance:

#### Cleaning

Dust the reflectors and combustion chamber and remove encrustations. Clean the ceramic tiles with dry air blower (do not use compressed air). Remove dirt from the electrode assembly.

#### Inspection

Following settings and components must be inspected:

- Check and correct nozzle pressure
- Check even distribution of load on the ceramic tiles
- Check quality of combustion - according to German standards: the max. CO content in flue gas is 1000 ppm. Comply with local standards!
- Check tiles for cracks
- Check radiation mesh and mesh support strip for wear
- Check electrodes for correct position or wear
- Check condition of combustion chamber and reflectors
- Check condition of mounting kit
- Check electrical connections
- Check all gas-carrying components (from ball valve gas connector to nozzle)
- Check operation of control system, switchbox

## **Eventual Defects**

The operator must be informed of any found defect and of the necessity of corrective maintenance and/or part replacements that must be done.

Maintenance of the actuators and flame monitoring modules as well as of other safety devices may only be performed by the manufacturer or by his representative. However, the appointed service technician is allowed to replace entire components or assemblies with appropriate parts.

The operator is recommended to sign a service contract in order to make sure a yearly maintenance of the heating installation is performed.

**At the end of a service and maintenance intervention, the entire installation must be switched on to confirm the correct operation of the heaters.**

## 12. Changeover to different gas type



**Before servicing and maintenance make sure to close the gas valve and cut electrical power to the heater off. The heater must be de-energized and secured against switching on!**

The changeover will be performed in the following steps:

- For new nozzle orifice, new air plate and new nozzle pressures see Ch. 16.
- Use open-end wrench size 24 and box-end wrench size 30 to unscrew nozzle piece **(2)**.
- Insert and fix new nozzle piece.
- Unscrew the 4 hexagonal screws M8 **(3)** from the nozzle housing **(4)**.
- Change air plate **(5)** (embossing to the outside)
- Fix nozzle housing again.
- Turn on gas and power.
- Adjust nozzle pressure accordingly.
- Close test nipple.
- Perform leak-test.
- Change the rating plate according to the current settings.

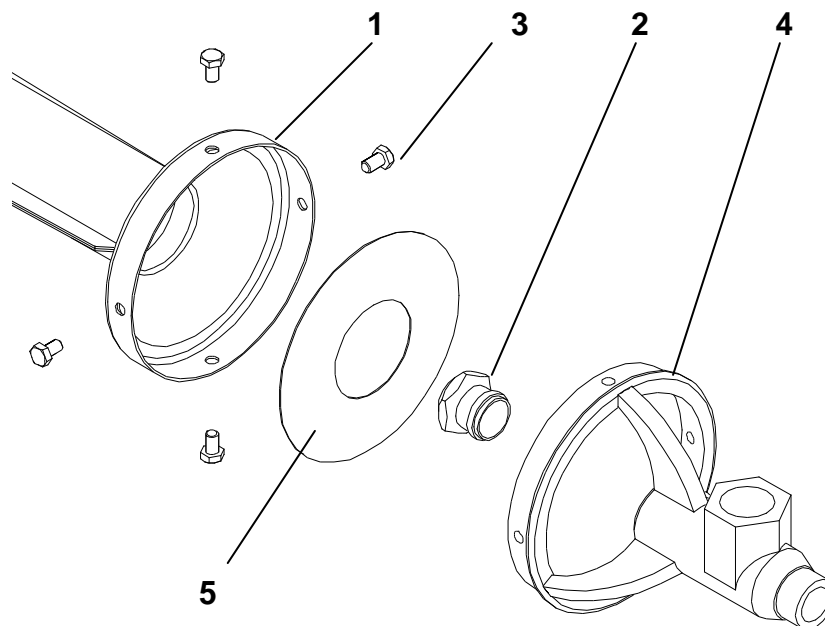

### 13. Setting Nozzle Pressure for One- and Two-Stage Heaters

---

- Switch heater on at full load.
- Open nozzle test nipple and connect measuring device.
- Open pressure regulator cap.
- Turn right – increase pressure / turn left – decrease pressure.
- Set correct nozzle pressure.
- Close pressure regulator cap.
- Close test nipple.

**Fig.** Combination Valve - Top View

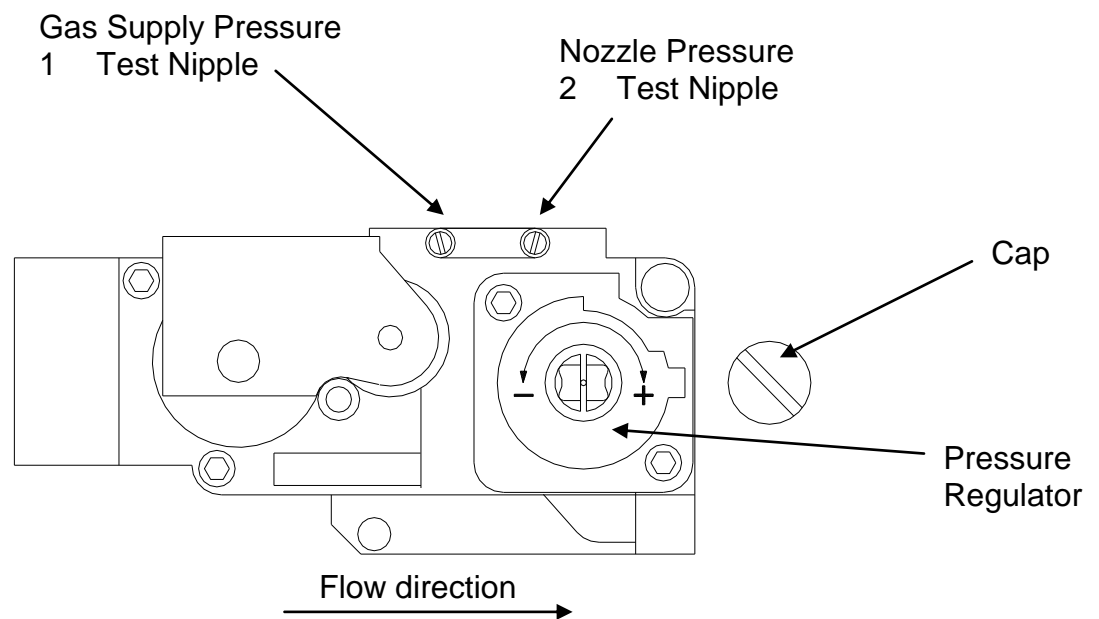

### 14. Minimum Mounting Height

---

The minimum heater to ground clearance is four meters. The higher the nominal input load of the heater, the larger need to be the distances to the ground. Applicable local codes and standards regarding minimum mounting height are to be complied with.

According to the German DVGW-Arbeitsblatt 638 Part 1, it is not allowed to expose people to unreasonable amounts of heat. This requirement is considered complied with when the following minimum mounting heights diagrams are respected.

**Diagram 1. Minimum Mounting Height for Horizontally Mounted Heaters**

Radiant coefficient  $\varphi_m = 2,5$  Radiant efficiency 60%

(max. radiant intensity, depending on air temperature at  $t_g = 17\text{ °C}$ , 1.7 m above ground)<sup>2</sup>

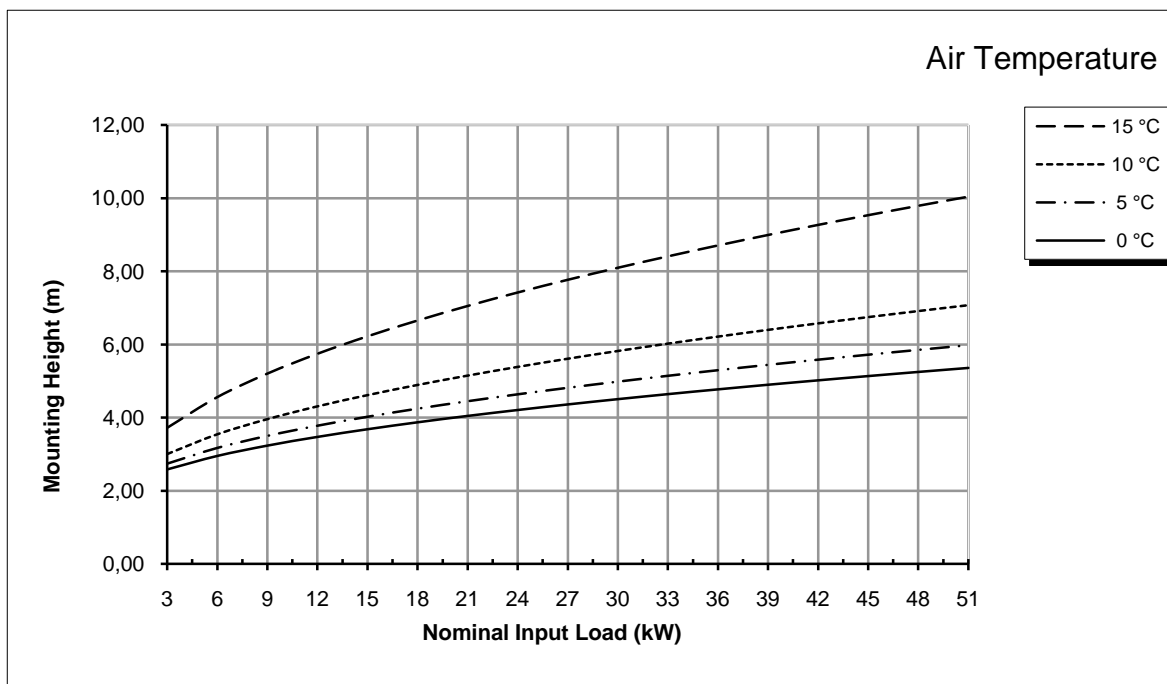

**Diagram 2. Minimum Mounting Height for Heaters Mounted at a 45° Angle**

Radiant coefficient  $\varphi_m = 2,5$  Radiant efficiency 60%

(max. radiant intensity, depending on air temperature at  $t_g = 17\text{ °C}$ , 1.7 m above ground)<sup>2</sup>

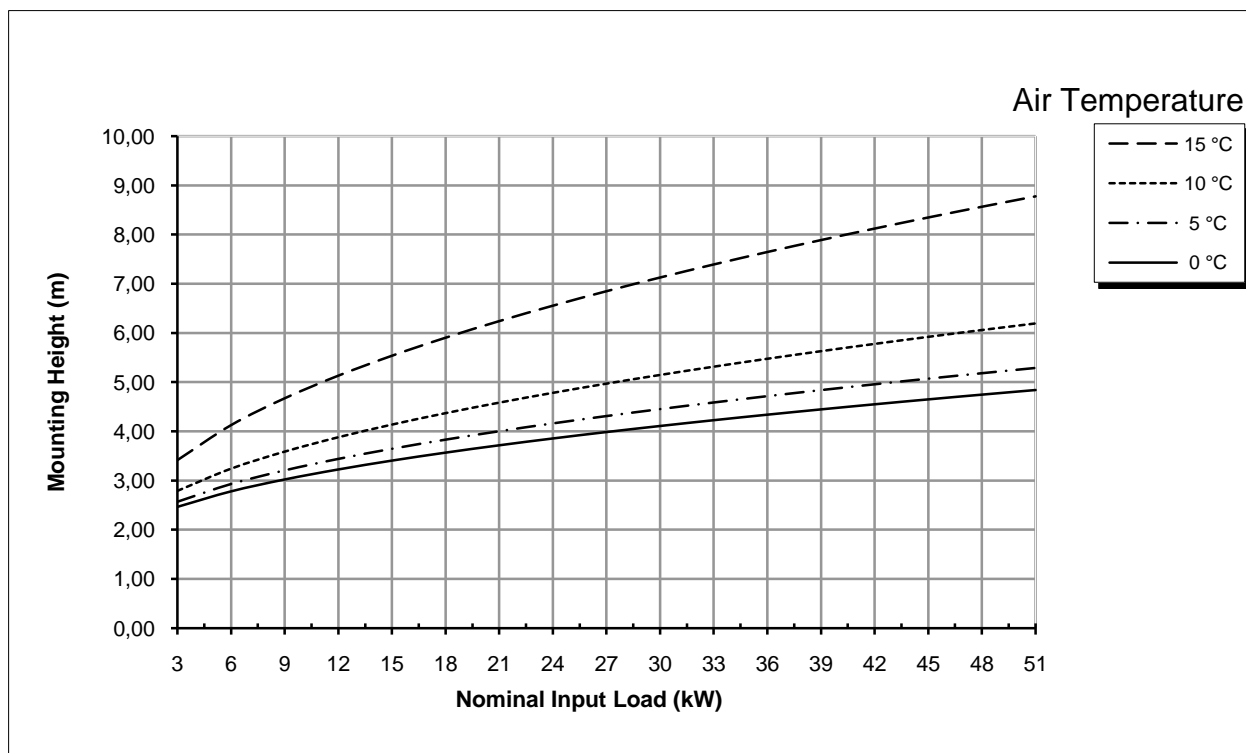

<sup>2</sup> Reference: Hj. Gebhardt, B.H. Müller, Th. Hettinger, B. Pause: *Physiologische Bewertung von Strahlungsheizungen*

## 15. Minimum Clearance to Combustibles

In Germany, the distances between heater and combustible materials (situated in directly as well as in indirectly radiated areas) must be large enough to ensure that the surfaces under the heater do not get hotter than 85°C. The allowed distances to combustibles are regulated in Germany in the DVGW 638 Part 1.

Applicable local codes and standards regarding minimum clearance to combustibles are to be complied with.

Should you have any questions or special requirements please contact GoGaS (see cover page).

**Diagram 3. Minimum Clearance to Combustibles in Radiated Areas**

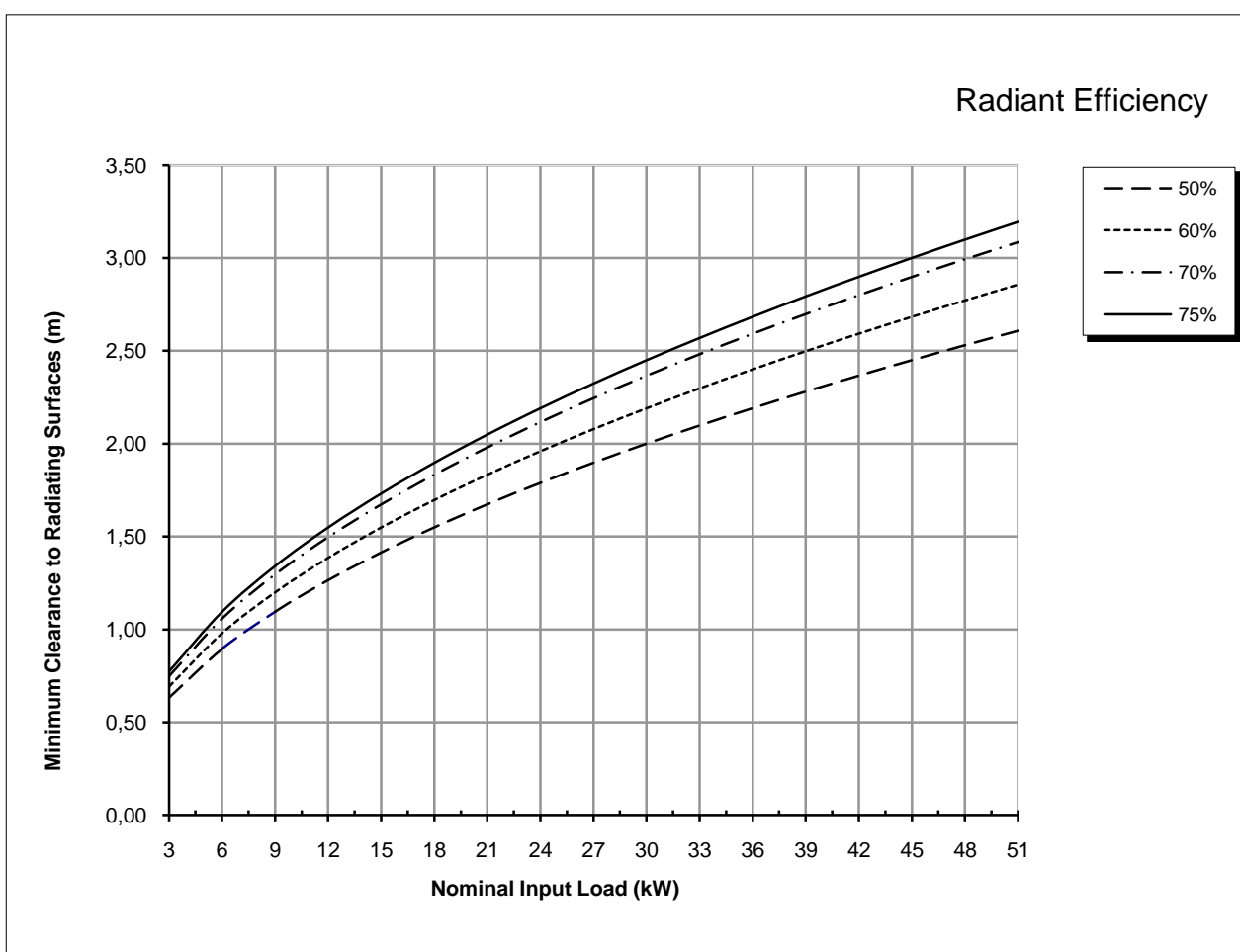

## 16. Nozzle Pressures Table (Manifold pressures)

### High Intensity Heater Series M Single- and Two-Stage

Type	Nominal Input Load kW	Gas Type	Min. Supply System Pressure mbar	Manifold pressure mbar	Nozzle Orifice $\varnothing$ mm	Air Plate $\varnothing$ mm
M 06	3 - 6	Nat. Gas G20	20	19,0	2 x 1,30	without
M 12	6 - 12	Nat. Gas G20	20	18,8	2 x 1,85	38
M 18	9 - 18	Nat. Gas G20	20	18,7	2 x 2,25	44
M 24	12 - 24	Nat. Gas G20	20	18,2	2 x 2,55	52
M 36	18 - 36	Nat. Gas G20	20	17,5	2 x 3,20	without
M 06	3 - 6	Nat. Gas G25	20	19,0	2 x 1,45	24
M 12	6 - 12	Nat. Gas G25	20	18,6	2 x 2,00	35
M 18	9 - 18	Nat. Gas G25	20	18,5	2 x 2,50	40
M 24	12 - 24	Nat. Gas G25	20	18,0	2 x 2,90	46
M 36	18 - 36	Nat. Gas G25	20	17,3	2 x 3,55	50
M 06	3 - 6	Propane G31	60	50	2 x 0,80	22
M 12	6 - 12	Propane G31	60	50	2 x 1,10	35
M 18	9 - 18	Propane G31	60	50	2 x 1,35	38
M 24	12 - 24	Propane G31	60	50	2 x 1,60	44
M 36	18 - 36	Propane G31	60	50	2 x 1,90	50

## 17. Technical Data

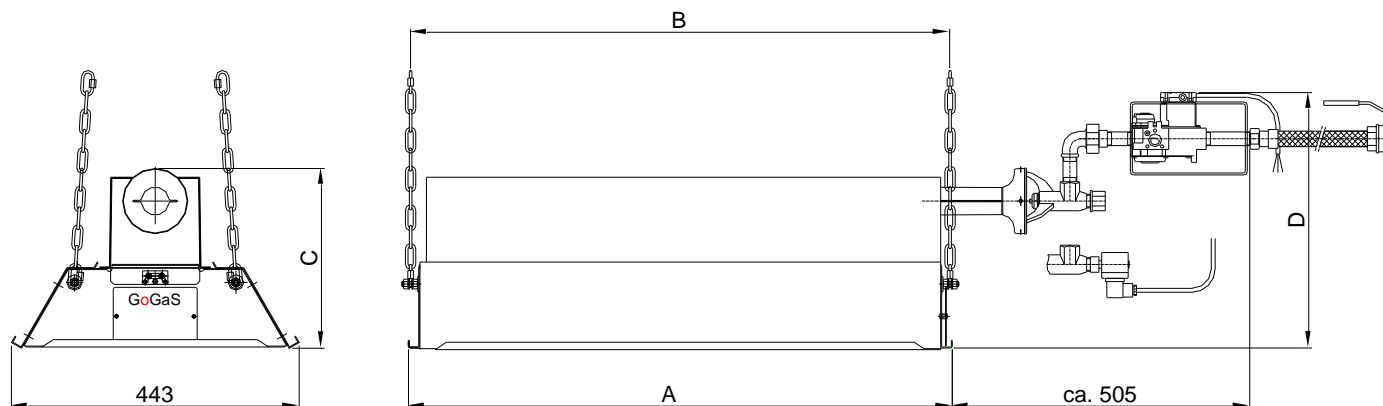

Type	Nominal Input Load kW	Gas Consumption Full - Half Load			Dimensions				
		G20 m <sup>3</sup> /h	G25 m <sup>3</sup> /h	G31 kg/h	A mm	B mm	C mm	D mm	Weight kg
M 06	3 - 6	0,30 - 0,60	0,35 - 0,70	0,23 - 0,47	484	476	290	410	7
M 12	6 - 12	0,60 - 1,20	0,70 - 1,40	0,47 - 0,93	853	845	280	400	13
M 18	9 - 18	0,90 - 1,81	1,05 - 2,10	0,70 - 1,40	1222	1214	280	400	17
M 24	12 - 24	1,20 - 2,41	1,40 - 2,80	0,93 - 1,87	1591	1583	270	390	22
M 36	18 - 36	1,81 - 3,61	2,10 - 4,20	1,40 - 2,80	2332	2324	270	390	31

Nat. Gas G20 ;                       $H_i = 9,97 \text{ kWh/m}^3$  ;    $W_s = 14,89 \text{ kWh/m}^3$

Nat. Gas G25 ;                       $H_i = 8,57 \text{ kWh/m}^3$  ;    $W_s = 12,15 \text{ kWh/m}^3$

Propane G31 ;                         $H_i = 12,87 \text{ kWh/kg}$  ;    $W_s = 22,55 \text{ kWh/m}^3$

Lower Heating Value  $H_i$  und Wobbe Index  $W_s$  bei 0° C und 1013 mbar

## 18. Spare Parts List

Pos.	GoGaS-Infrarotstrahler M Bezeichnung	Art.-Nr.	Leistungstypen				
			06	12	18	24	36
1	Reflector M 06	10218001	1				
1	Reflector M 12	10218002		1			
1	Reflector M 18	10218003			1		
1	Reflector M 24	10218004				1	
1	Reflector M 36	10218005					1
2	Combustion chamber N 06-Effekt	21206001	1				
2	Combustion chamber N 12-Effekt	21206002		1			
2	Combustion chamber N 18-Effekt	21206003			1		
2	Combustion chamber N 24-Effekt	21206004				1	
2	Combustion chamber N 36-Effekt	21206005					1
4	Cylinder screw w. slot M5 x 16	30601015	2	2	2	2	2
5	Hex. nut M 5 A2	30604007	2	2	2	2	2
6	Nozzle housing N06-36	32201118	1	1	1	1	1
7	Double nipple R1/2" x 60	31204010	1	1	1	1	1
8	Elbow connector R1/2"	31203015	1	1	1	1	1
9	Cover R1/2" verz.	31202041	1	1	1	1	1
10*	Double nozzle KMI / M	xxxxxxxx	1	1	1	1	1
11*	Air plate	xxxxxxxx	1	1	1	1	1
12	High- low valve	21004005	1	1	1	1	1

\* When ordering Items 10 and 11 always specify heater input load and gas type.

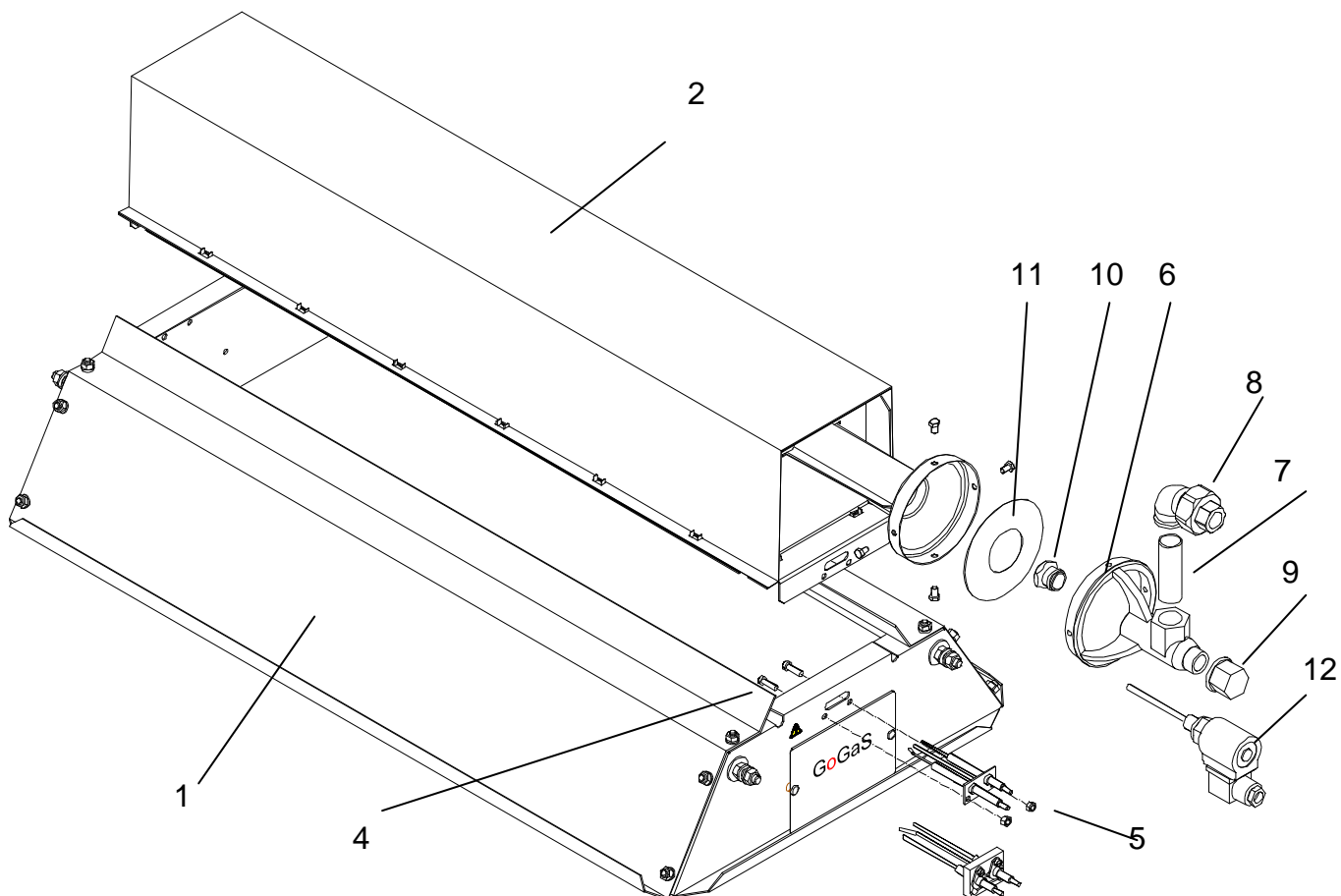

Control unit and gas train M Series			Series SR 3010	
Pos.	Description	Art.-Nr.	one-stage	two-stage
1	Controller SG 300	32001125	1	1
2	Combination valve 1-stage VK 4115	31402087	1	1
3	Connector with cable	31402089	1	1
4	Double nipple, galvanized R1/2"x80	31204100	1	1
5	Double nipple, galvanized R1/2"x60	31204010	1	1
6	Ignition wire 650 mm long	21001046	1	1
7	Cable with connector for 4 mm pin	31902211	1	1
8	Ground lead with extra wire	31901124	1	1
9	Hex. screw M 4 x 10 w. slot	30602198	2	2
10	Hex. nut M 5 A 2	30604007	1	1
11	Electrode assebly	21001045	1	1
<b>Complete control unit and gas train</b>				
	Type SR 3010/ELL-1 stage (G20, G25)	10306126	1	
	Type SR 3010/ELL-2 stage (G20, G25)	10306127		1
	Type SR 3010/P-1 stage (G31)	10306128	1	
	Type SR 3010/P-2 stage (G31)	10306129		1

