

Magnetic relief valve VAN

Product brochure · GB
3.1.3 Edition 03.10



krom
schroder



- Open when de-energized
- Connection flanges for pipes up to DN 50
- Suitable for a maximum inlet pressure of 500 mbar (7 psig)
- Space-saving installation thanks to compact dimensions
- Quick closing, quick opening
- Check indication by blue LED
- Position indicator with visual indicator
- EC type-tested and certified



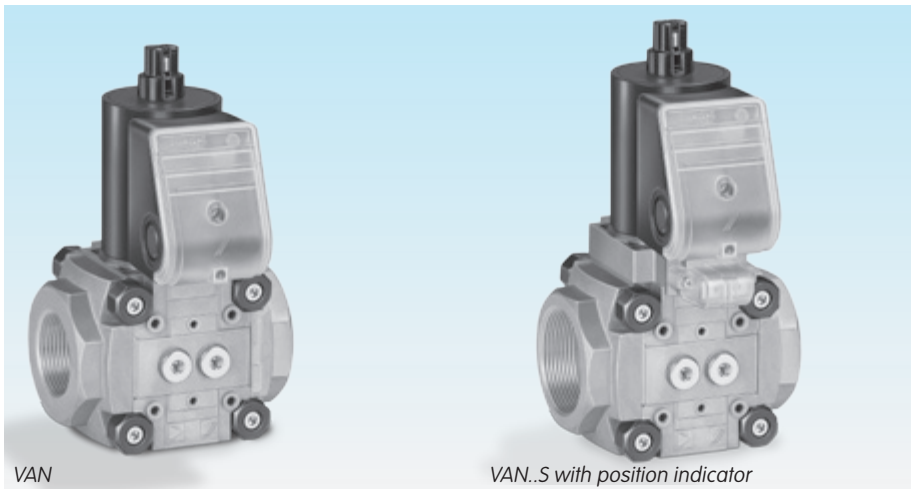

VAN

VAN..S with position indicator

Application

The magnetic relief valve VAN is designed to monitor gas valves for tightness used in conjunction with a visual discharge unit. It enables the purging of excess or leakage gas. The magnetic relief valve VAN is open when it is de-energized.

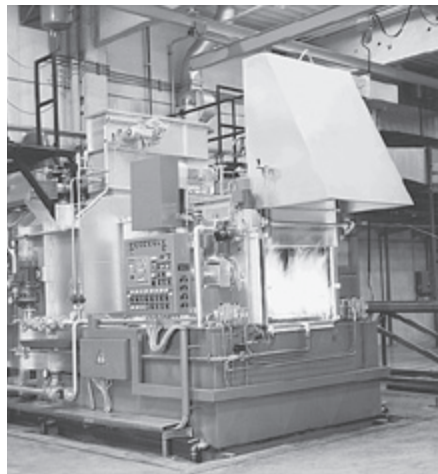

Forging furnace

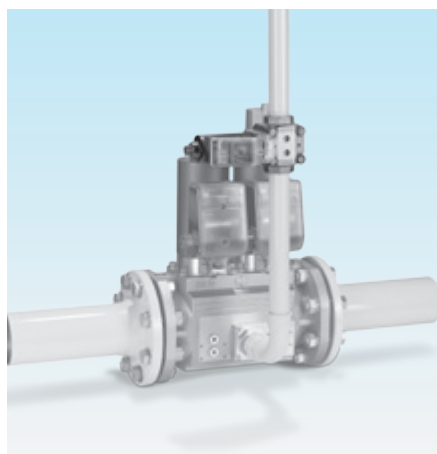

Roller hearth furnace

Magnetic relief valve
VAN on the double
solenoid valve VCS

Examples of application

Relief valve with two gas solenoid valves and tightness control

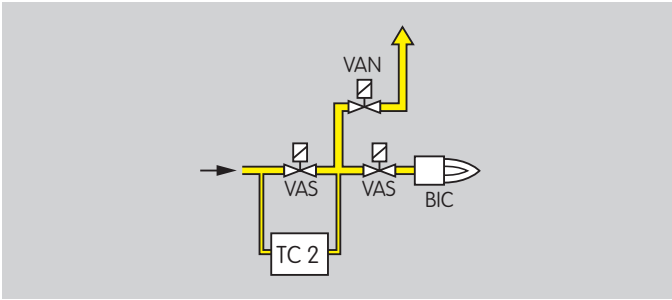

Tightness control TC 2 checks the gas solenoid valves VAS and the magnetic relief valve VAN for tightness.

If the gas solenoid valves and the magnetic relief valve are tight, the tightness control forwards an enable signal to the automatic burner control unit. The pilot valve output of the automatic burner control unit opens the gas solenoid valves VAS simultaneously. The burner starts.

In accordance with the Russian safety regulations PB 12-529-03, installations with a capacity of ≥ 1.2 MW must be fitted with a relief valve and tightness control.

Relief valve with 2 gas solenoid valves

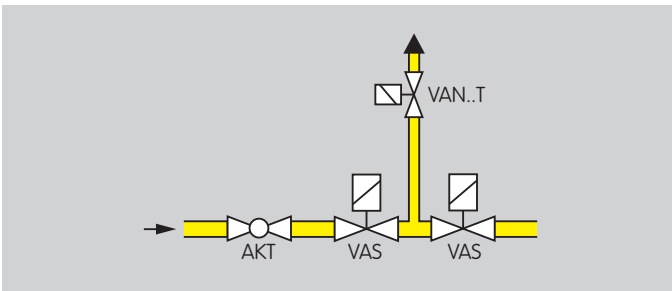

A valve, open when de-energized, is designed to purge gas to a safe venting point. For the NAFTA market, this applies for capacities of ≥ 117 kW (400,000 BTU/h).

Inert gas atmosphere for annealing processes

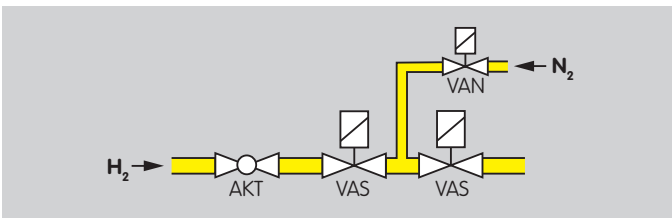

Whenever no hydrogen is needed for the annealing process (e.g. in the case of an annealing bell), the gas solenoid valves VAS and the magnetic relief valve VAN are disconnected from the electrical power supply. The VAN opens. Under high pressure, nitrogen can now get between the two gas solenoid valves VAS. This prevents hydrogen from flowing into the furnace.

Replacement possibilities

VAN 15–40/32 is to be replaced by VAN 110–250.

Type code

Code	Description
VAN	Magnetic relief valve
1	Size: 1
2	2
T	T-product
10	Nominal diameter [DN]: 10
15	15
20	20
25	25
32	32
40	40
50	50
R	Rp internal thread
N	NPT internal thread
/N	Quick opening, quick closing
K	Mains voltage: 24 V DC
P	100 V AC, 50/60 Hz
Q	120 V AC, 50/60 Hz
Y	200 V AC, 50/60 Hz
W	230 V AC, 50/60 Hz
S	Position indicator: with visual indicator
G	with visual indicator and gold contacts
R	Viewing side: right
L	left
3	Electrical connection: M20 cable gland

Flow rate

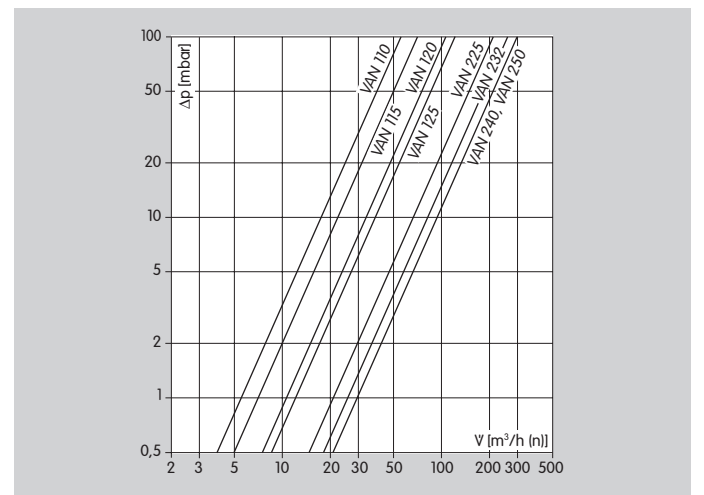

Technical data

Gas types: natural gas, LPG (gaseous), biologically produced methane (max. 0.1 %-by-vol. H₂S) or air; other gases on request.

The gas must be dry in all temperature conditions and must not contain condensate.

Max. inlet pressure pe: 500 mbar (7 psig).

Closing time: quick closing: < 1 s.

Ambient temperature: -20 to +50°C (-4 to +122°F), for short periods up to +60°C (140°F), storage temperature: 0–60°C (32–140°F), no condensation permitted.

Safety valve:

Class A Group 2 pursuant to EN 13611 and EN 161.

Mains voltage:

230 V AC, +10/-15%, 50/60 Hz;
200 V AC, +10/-15%, 50/60 Hz;
120 V AC, +10/-15%, 50/60 Hz;
100 V AC, +10/-15%, 50/60 Hz;
24 V DC, ±20%.

Cable gland: M20 x 1.5.

Electrical connection: cable with max.

2.5 mm² (AWG 12) or plug with socket to EN 175301-803.

Power consumption:

Type	24 V DC [W]	100 V AC [W]	120 V AC [W]	200 V AC [W]	230 V AC [W]
VAN 1	29	33	30	33	30
VAN 2	46	53	54	34	53

Enclosure: IP 65.

Duty cycle: 100%.

Power factor of the solenoid coil: $\cos \varphi = 1$.

Switching frequency: any.

Valve housing: aluminium,

Valve seal: NBR.

Connection flanges: Rp to ISO 7-1, NPT to ANSI/ASME.

Position indicator contact rating:

Type	Voltage	Min. current (resistive load)	Max. current (resistive load)
VAN..S	100 – 250 V AC, 50/60 Hz	100 mA	3 A
VAN..G	12 – 48 V AC, 50/60 Hz	2 mA	0.1 A

Switching frequency: 5 x per minute.

Switching current [A]	Switching cycles*	
	$\cos \varphi = 1$	$\cos \varphi = 0.6$
0.1	500,000	500,000
0.5	300,000	250,000
1	200,000	100,000
3	100,000	–

* Limited to max. 200,000 cycles for heating systems.

Detailed information on this product

www.docuthek.com → Elster Kromschroder

Search term: VAN

Kind of document: Technical information

Contact

www.kromschroeder.com → Sales

Elster GmbH
Postfach 2809 · 49018 Osnabrück
Strothweg 1 · 49504 Lotte (Büren)
Germany

T +49 541 1214-0
F +49 541 1214-370
info@kromschroeder.com
www.kromschroeder.com
www.elster.com

Kromschroder, a product
brand of the Elster Group

**krom
schroder**

We reserve the right to make technical modifications
in the interests of progress.

Copyright © 2007–2009 Elster Group
All rights reserved.